

**YAMAHA**

**GENUINE**

**PARTS CATALOGUE**

**MOTORCYCLE**

# CYLINDER

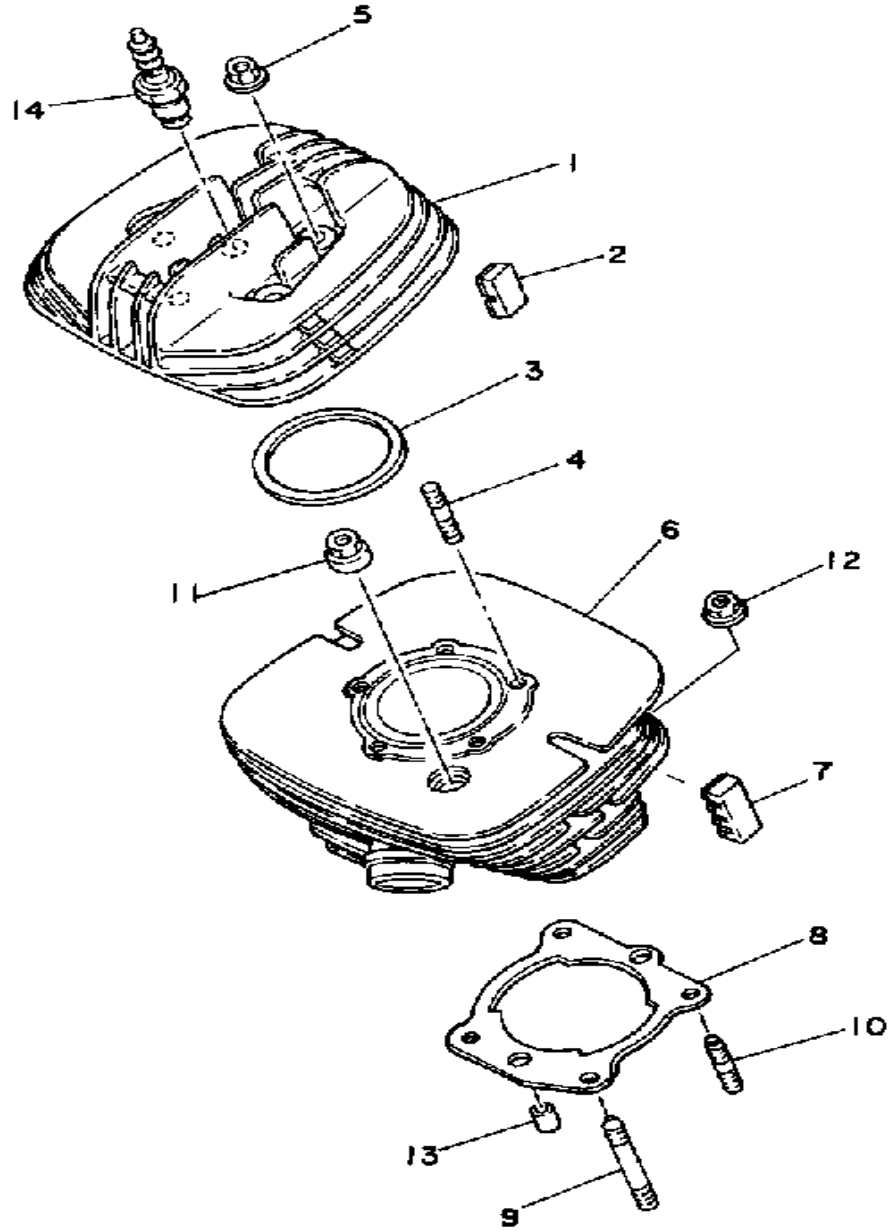

Ref. No.	Part Number	Description	Qty	Remarks
1	3R6-11111-00-00	HEAD, CYLINDER 1	1	
2	3R6-11161-00-00	ABSORBER 1	4	
3	3R6-11181-00-00	GASKET, CYLINDER HEAD 1	1	
4	90116-08321-00	BOLT, STUD	5	
5	90179-08491-00	NUT, FLANGE	5	
6	3R6-11311-00-00	CYLINDER 1	1	
7	3R6-11162-00-00	ABSORBER 2	4	
8	3R3-11351-00-00	GASKET, CYLINDER	1	
9	90116-08319-00	BOLT, STUD	1	
10	90116-08318-00	BOLT, STUD	3	
11	90179-08268-00	NUT	1	
12	90179-08491-00	NUT, FLANGE	3	
13	99530-10014-00	PIN, DOWEL	2	
14	(CMP-N2G00-00-00)	CHAMPION N2G 10PK	1	

Spark Plug Type	Champion N-2G
Spark Plug Gap / Torque / Cap $\Omega$	0.7mm / 2.5 m $\cdot$ kg / $\emptyset$
Bore / Stroke / Number Cylinders / Displacement (cc)	66mm / 50mm / 1 / 171cc
Compression Ratio / Compression Pressure Min~Max	7.9: 1 / $\emptyset$

# CRANKSHAFT - PISTON

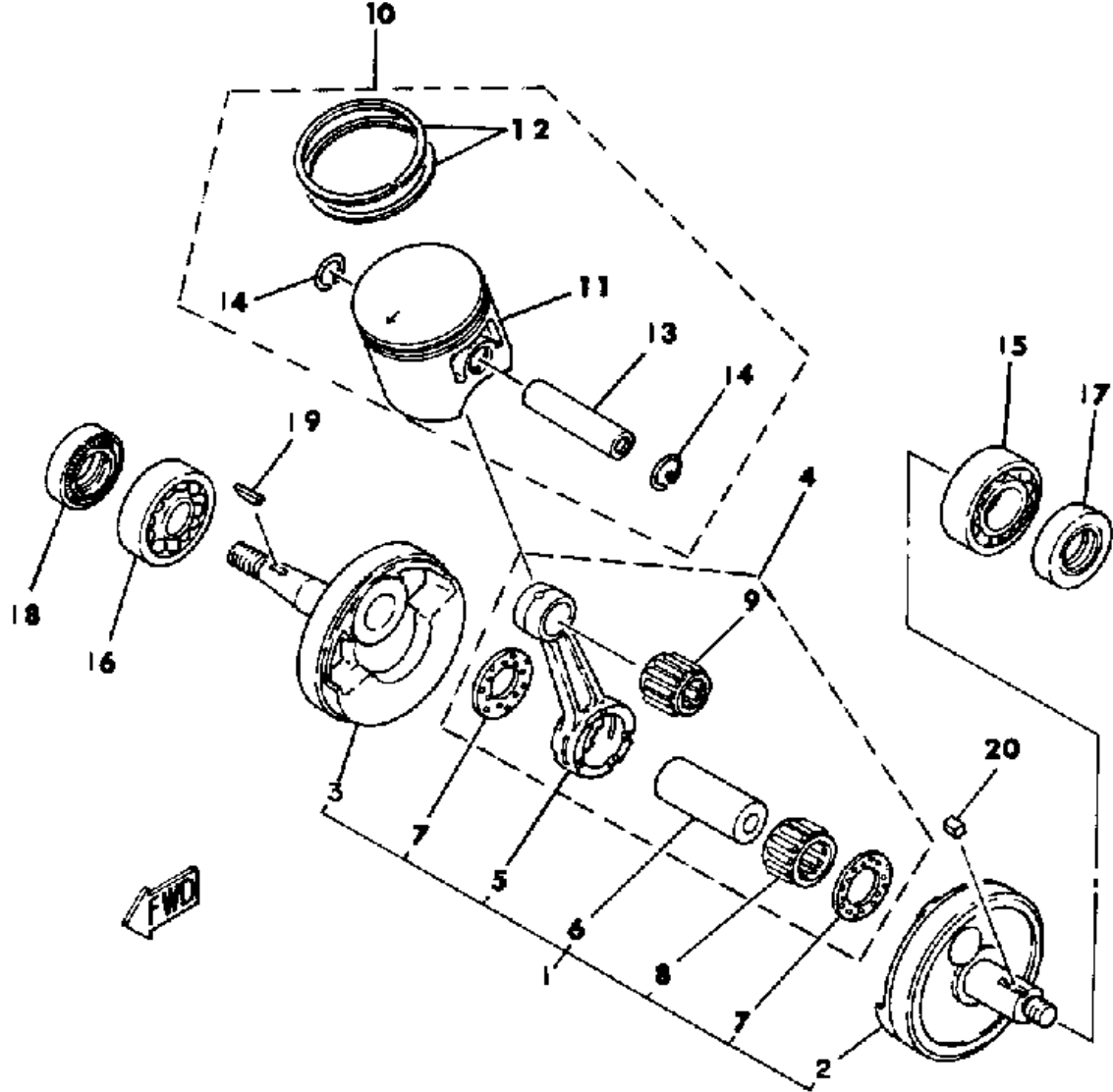

Piston Skirt Clearance New / Max	0.060 ~ 0.056mm / 0.1mm
Ring End Gap Top / 2nd / 3rd	0.2 ~ 0.4mm / 0.2 ~ 0.4mm / ø

Ref. No.	Part Number	Description	Qty	Remarks
1	3R6-11400-00-00	CRANKSHAFT ASSEMBLY	1	
2	3R3-11412-00-00	. CRANK 1	1	
3	3R6-11422-00-00	. CRANK 2	1	
4	3R2-11650-01-00	. CONNECTING ROD ASSEMBLY (3M5-11650-10)	1	ASSEMBLY
5	3R2-11651-01-00	.. ROD, CONNECTING	1	
6	3M5-11681-00-00	.. PIN, CRANK 1	1	
7	90209-22248-00	.. WASHER	2	
8	93310-422H0-00	.. BEARING, CYLINDER.# 0	1	
9	93310-216E1-00	. BEARING	1	
10	3R6-11630-00-00	PISTON KIT STD	1	ASSEMBLY
11	3R6-11631-00-96	. PISTON STD	1	
12	3JM-11601-00-00	. PISTON RING SET (STD)	1	
13	251-11633-00-00	. PIN, PISTON	1	
14	93450-17025-00	. CIRCLIP	2	
15	93306-30421-00	BEARING (B6304C3)	1	
16	93306-20529-00	BEARING (B6205C4)	1	
17	93103-28011-00	OIL SEAL	1	
18	93102-25258-00	OIL SEAL, SD-TYPE	1	
19	90280-03017-00	KEY, WOODRUFF	1	
20	(3R6-11630-20-00)	PISTON KIT 2ND	1	
	(3R6-11630-30-00)	PISTON KIT 3RD	1	
	3JM-11601-10-00	PISTON RING SET (0.25MM O/S)	1	
	3JM-11601-20-00	PISTON RING SET (0.50MM O/S)	1	
	3R6-11630-10-00	PISTON KIT 1ST	1	
	3R6-11630-40-00	PISTON KIT 4TH	1	
	3R6-11635-00-00	PISTON 1 O/S 0.5	1	
	3R6-11636-00-00	PISTON 2 O/S 0.0	1	

CONTINUED ON NEXT FRAME ➤

# CRANKSHAFT - PISTON

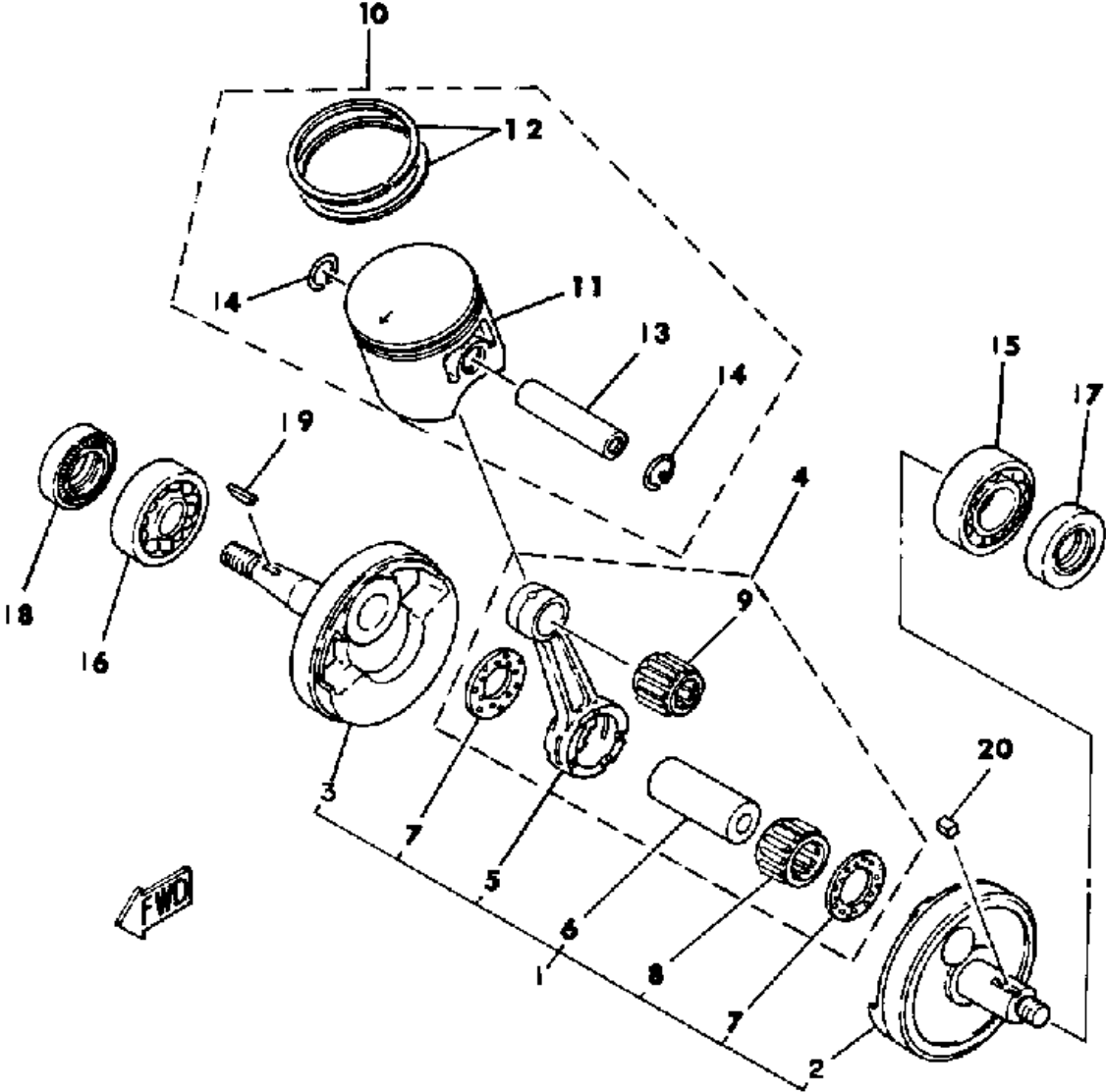

Ref. No.	Part Number	Description	Qty	Remarks
20	3R6-11637-00-00	PISTON 3 O/S 0.5	1	
	3R6-11638-00-00	PISTON 4 O/S 1.0	1	
	43G-11601-30-00	PISTON RINGSET 3RD	1	
	43G-11601-40-00	PISTON RINGSET 4TH	1	
	90282-05038-00	KEY, STRAIGHT	1	

Piston Skirt Clearance New / Max	0.060 ~ 0.056mm / 0.1mm
Ring End Gap Top / 2nd / 3rd	0.2 ~ 0.4mm / 0.2 ~ 0.4mm / ø

# C - D - I - MAGNETO

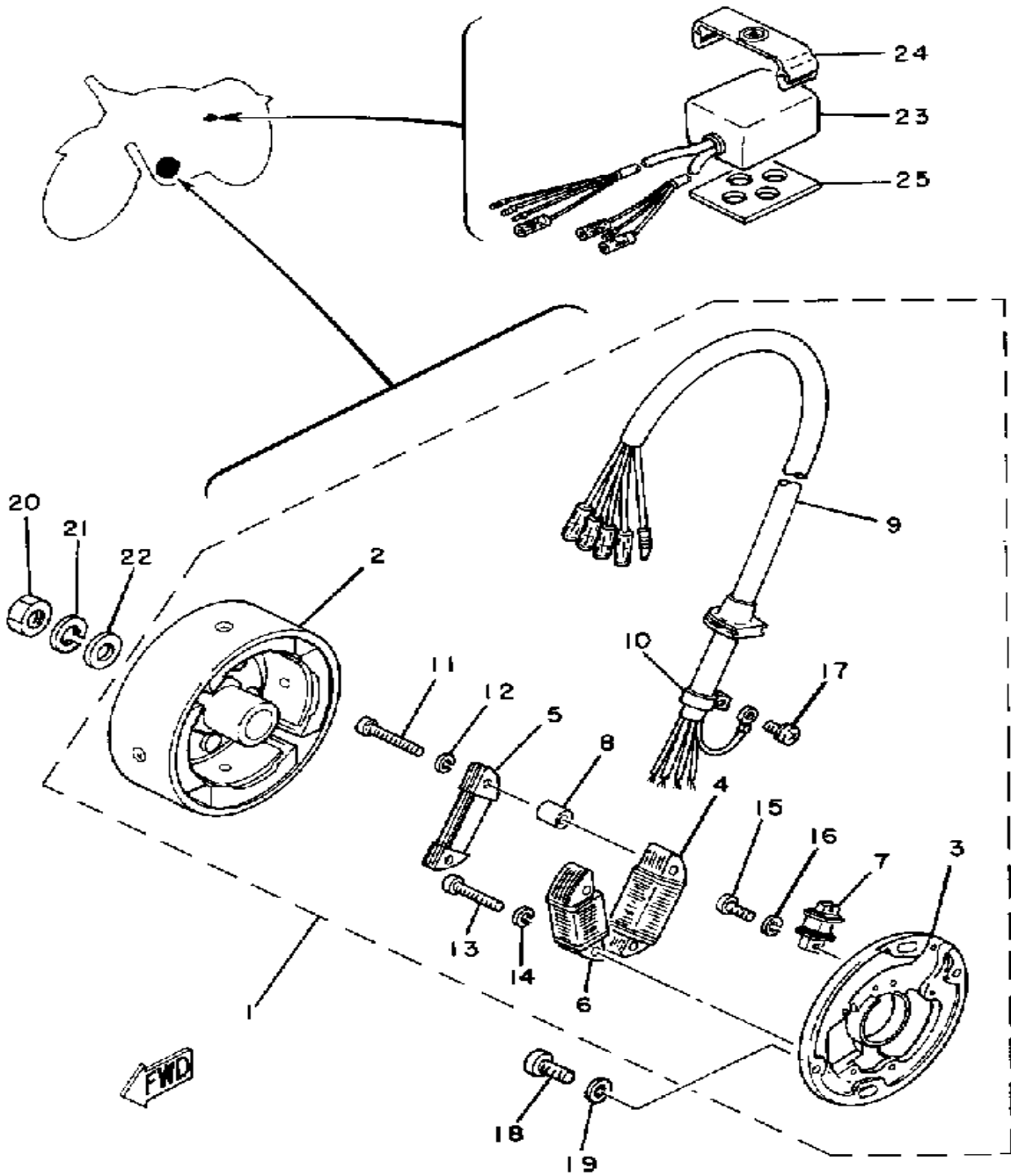

Ref. No.	Part Number	Description	Qty	Remarks
1	3R6-85500-20-00	CDI MAGNETO ASSEMBLY ...	1	
2	3R6-85550-20-00	. ROTOR ASSEMBLY .....	1	
3	3R5-85509-20-00	. BASE, MAGNETO .....	1	
4	3R5-85511-20-00	. COIL SOURCE 1 .....	1	
5	3R5-85512-20-00	. COIL SOURCE 2 .....	1	
6	1W2-85513-20-00	. COIL, LIGHTING 1 .....	1	
7	3R6-85580-20-00	. COIL, PULSER .....	1	
8	1W2-85516-20-00	. SPACER .....	2	
9	(3R6-85515-20-00)	LEAD WIRE ASSEMBLY .....	1	
10	104-81328-20-00	. CLAMP .....	1	
11	98501-04035-00	. SCREW, PAN HEAD .....	2	
12	92901-04100-00	. WASHER, SPRING .....	2	
13	98511-04030-00	. SCREW, PAN HEAD .....	2	
14	92901-04100-00	. WASHER, SPRING .....	2	
15	98503-04014-00	. SCREW, PAN HEAD .....	1	
16	92901-04100-00	. WASHER, SPRING .....	1	
17	97601-04106-00	. SCREW, PN/HD.W/WSHR ...	1	
18	98503-06014-00	SCREW, PAN HEAD (92502-06016) .....	2	
19	92901-06600-00	WASHER .....	2	
20	90170-12347-00	NUT, HEXAGON .....	1	
21	92901-12100-00	WASHER, SPRING .....	1	
22	90201-12593-00	WASHER, PLATE .....	1	
23	2W6-85540-20-00	CDI UNIT ASSEMBLY .....	1	
24	21V-21376-00-00	BAND, TOOL .....	1	
25	2K7-85547-00-00	DAMPER .....	1	

# INTAKE

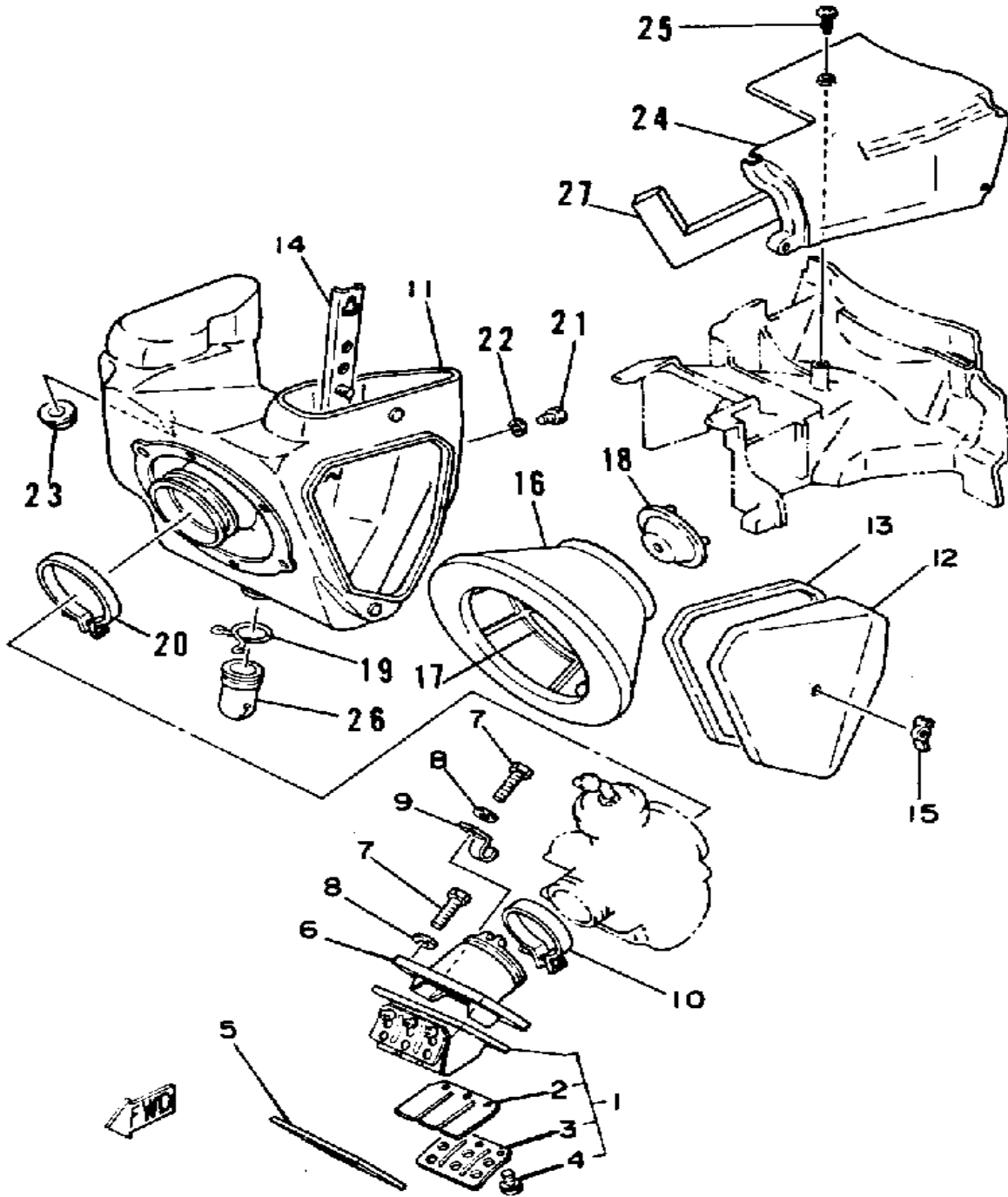

Ref. No.	Part Number	Description	Qty	Remarks
1	43G-13610-00-00	REED VALVE ASSEMBLY	1	
2	3R3-13613-00-00	. REED, VALVE	2	
3	43G-13616-00-00	. STOPPER, REED VALVE	2	
4	98580-03008-00	. SCREW, PAN HEAD	6	
5	3R3-13621-00-00	GASKET, VALVE SEAT	1	
6	3R3-13565-00-00	JOINT, CARBURETOR	1	
7	97011-06025-00	BOLT (97001-06025)	4	
8	92901-06600-00	WASHER	4	
9	90462-05005-00	CLAMP	1	
10	90460-49058-00	CLAMP, HOSE	1	
11	(3R6-14401-01-00)	AIR CLNR CASE ASSEMBLY	1	
12	3R3-14412-01-00	CAP, CLEANER CASE 1	1	
13	50M-14462-01-00	SEAL	1	
14	3R3-14494-00-00	STAY 2	1	
15	90175-06008-00	NUT, WING	1	
16	3R3-W1442-01-00	ELEMENT, AIR CLNR	1	
17	3R3-14458-00-00	GUIDE, ELEMENT	1	
18	(3R3-14468-00-00)	PLATE, ELEMENT FTNG	1	
19	90467-20030-00	CLIP	1	
20	90460-64065-00	CLAMP, HOSE	1	
21	97013-06012-00	BOLT	2	
22	92995-06100-00	WASHER, SPRING	2	
23	90480-13398-00	GROMMET	1	
24	(3R6-14437-00-00)	DUCT	1	
25	97702-50116-00	SCREW, TAPPING	3	
26	1W4-14457-00-00	SEAL	1	
27	(3R6-14457-00-00)	SEAL	1	

# CARBURETOR

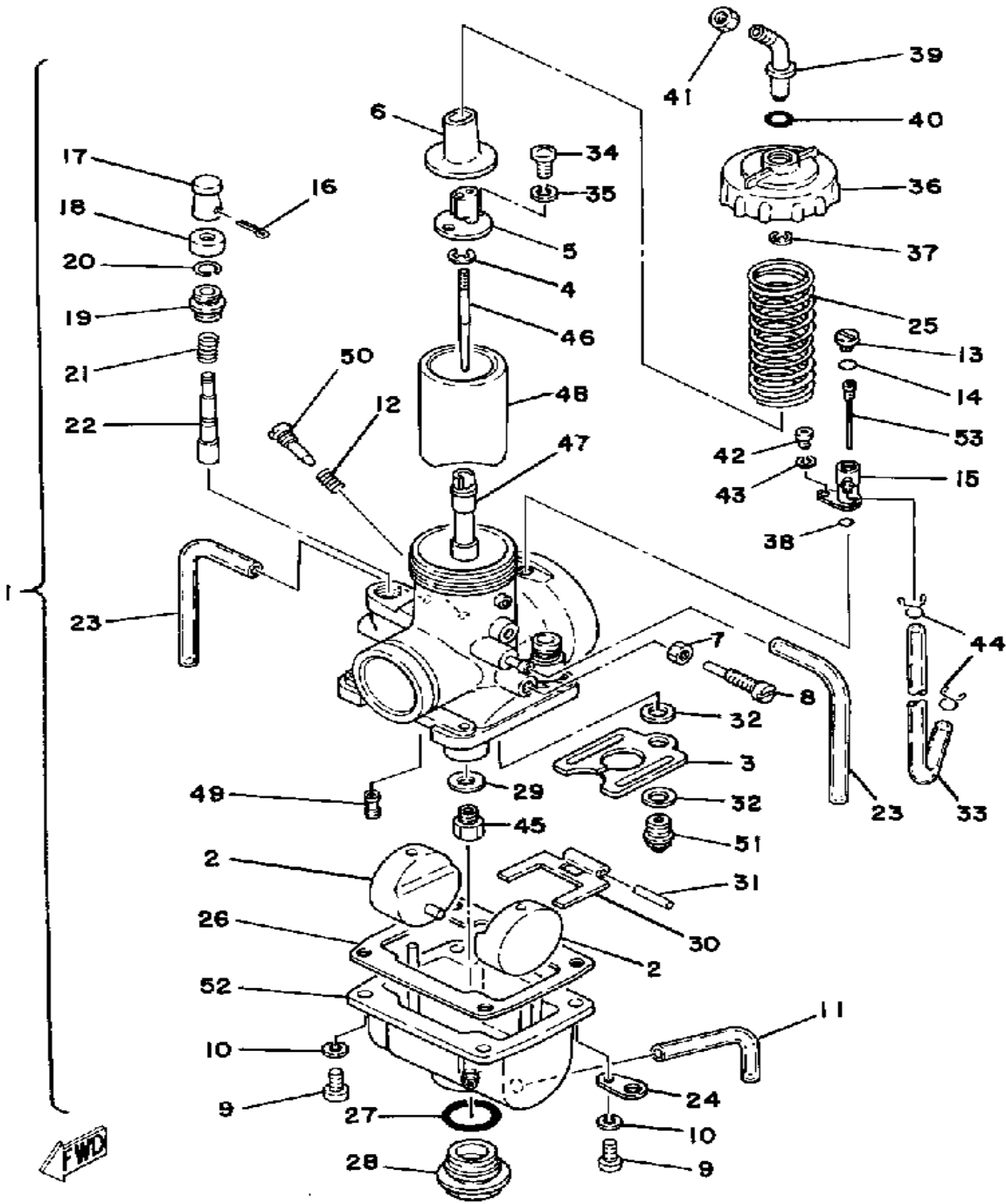

Ref. No.	Part Number	Description	Qty	Remarks
1	3R6-14101-00-00	CARBURETOR ASSEMBLY 1	1	
2	310-14185-00-00	. FLOAT	1	
3	483-14146-00-00	. PLATE	1	
4	164-14137-00-00	. CLIP	1	
5	509-14274-00-00	. CONNECTOR	1	
6	509-14136-00-00	. SEAT, SPRING	1	
7	802-14161-00-00	. NUT, CABLE ADJUSTING	1	
8	24X-14103-00-00	. THROTTLE SCREW SET	1	
9	98580-05016-00	. SCREW, PAN HEAD	4	
10	92990-05100-00	. WASHER, SPRING	4	
11	2J2-14196-00-00	. PIPE	1	
12	127-14134-00-00	. SPRING, AIR ADJUSTING	1	
13	3G2-14115-00-00	. PLUG, SCREW	1	
14	822-14147-00-00	. O-RING	1	
15	1X2-14244-00-00	. HOLDER, NOZZLE	1	
16	91490-16020-00	. PIN, COTTER	1	
17	737-14261-00-00	. HOLDER	1	
18	637-14173-00-00	. COVER, PLUNGER CAP	1	
19	152-14174-00-00	. CAP, PLUNGER	1	
20	353-14138-00-00	. CLIP, PLUNGER	1	
21	132-14135-00-00	. SPRING, PLUNGER	1	
22	737-14171-01-00	. PLUNGER, STARTER	1	
23	310-14197-00-00	. PIPE, AIRVENT	2	
24	313-14146-00-00	. PLATE	2	
25	363-14131-00-00	. SPRING, THROTTLE VALVE	1	
26	483-14184-00-00	. GASKET, FLOAT CHMBR	1	
27	2K6-14147-00-00	. O-RING	1	
28	2K6-14115-00-00	. PLUG, SCREW	1	
29	(537-14153-00-00)	WASHER, MAIN JET	1	

CONTINUED ON NEXT FRAME ➤

# CARBURETOR

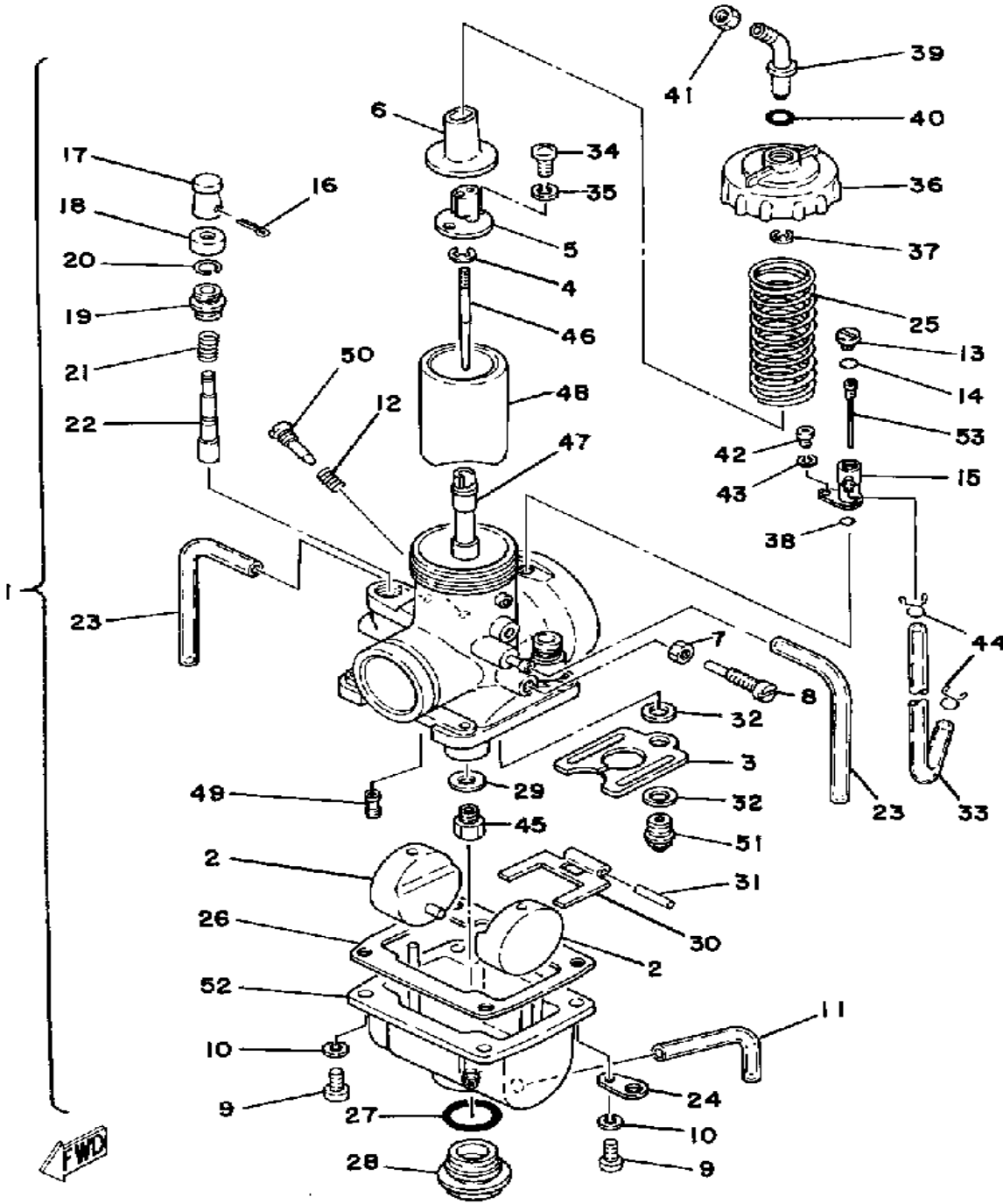

Ref. No.	Part Number	Description	Qty	Remarks
30	310-14187-00-00	. ARM, FLOAT .....	1	
31	537-14186-00-00	. PIN, FLOAT .....	1	
32	239-14195-00-00	. WASHER, NEEDLE VALVE ..	2	
33	3V3-14987-00-00	. HOSE .....	1	
34	98580-03008-00	. SCREW, PAN HEAD .....	2	
35	92990-03100-00	. WASHER, SPRING (92901-03100) .....	2	
36	3R3-14158-00-00	. TOP, MIXING CHAMBER .....	1	
37	363-14137-00-00	. CLIP .....	1	
38	214-14147-00-00	. O-RING .....	1	
39	24X-14106-00-00	. CBLE AJST SCRW SETSCREW SET .....	1	
40	8F2-14147-00-00	. O-RING .....	1	
41	127-14161-00-00	. NUT, CABLE ADJUSTING ...	1	
42	98580-04008-00	. SCREW, PAN HEAD .....	1	
43	92901-04100-00	. WASHER, SPRING .....	1	
44	8A7-14139-00-00	. CLIP, PIPE .....	2	
45	137-14143-40-A1	. JET, MAIN #2 0 .....	1	U.R.
	137-14143-42-A1	. JET, MAIN #2 0 .....	1	U.R.
	137-14143-44-A1	. JET, MAIN #2 0 .....	1	U.R.
46	239-14116-21-00	. NEEDLE (6F21-3) .....	1	
47	239-14141-48-00	. NOZZLE, MAIN P 8 .....	1	
48	3R6-14112-20-00	. VALVE, THROTTLE 1 .....	1	
49	193-14142-60-00	. JET, PILOT #60 (60) .....	1	
50	23X-14104-00-00	. AIR SCREW SET .....	1	
51	24X-14107-33-00	. NEEDLE VALVE SET (#3.3) ..	1	
52	(3R6-14181-16-00)	BODY, FLOAT CHMBR 1 .....	1	
53	3G2-1423A-67-00	. JET, MAIN #825 (#82.5) .....	1	



# EXHAUST

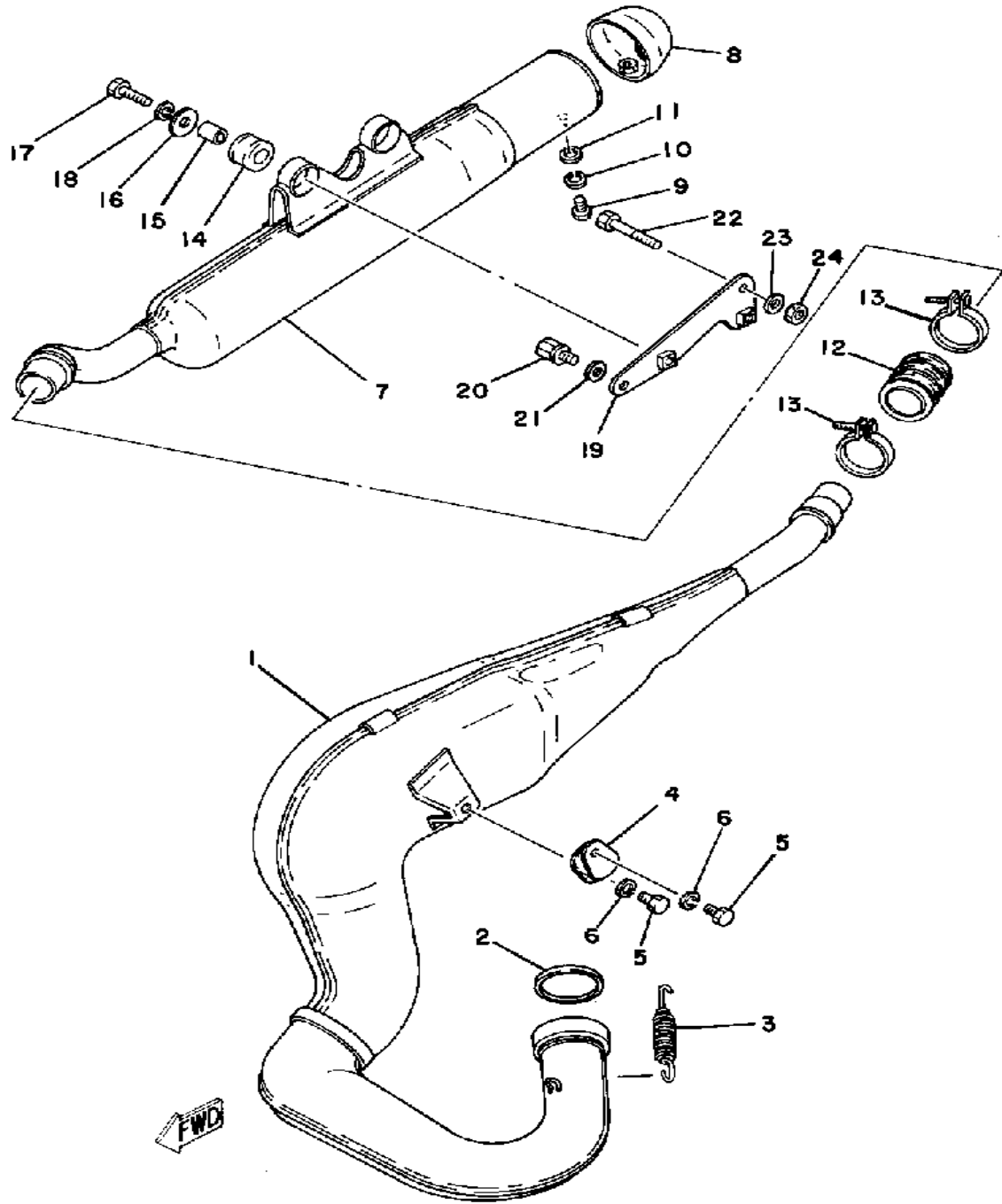

Ref. No.	Part Number	Description	Qty	Remarks
1	3R6-14610-00-00	EXHAUST PIPE ASSEMBLY L .	1	
2	3R6-14613-01-00	GASKET, EXST PIPE . . . . .	1	
3	90507-20030-00	SPRING, TENSION . . . . .	2	
4	565-14771-00-00	STAY, MUFFLER 1 . . . . .	1	
5	97013-06012-00	BOLT . . . . .	2	
6	92995-06100-00	WASHER, SPRING . . . . .	2	
7	(3R6-14753-00-00)	SILENCER, EXHAUST . . . . .	1	
8	1W2-14787-00-00	CAP, SILENCER . . . . .	1	
9	97013-06012-00	BOLT . . . . .	1	
10	92995-06100-00	WASHER, SPRING . . . . .	1	
11	92901-06600-00	WASHER . . . . .	1	
12	1W2-14714-00-00	GASKET, MUFFLER . . . . .	1	
13	90460-37026-00	CLAMP, HOSE . . . . .	2	
14	90480-22269-00	GROMMET . . . . .	2	
15	90387-081A3-00	COLLAR . . . . .	2	
16	90201-085E6-00	WASHER PLATE . . . . .	2	
17	97313-08030-00	BOLT, HEXAGON . . . . .	2	
18	92990-08100-00	WASHER . . . . .	2	
19	3R6-14781-00-00	STAY, MUFFLER 2 . . . . .	1	
20	90109-08573-00	BOLT . . . . .	1	
21	92990-08200-00	WASHER, PLAIN . . . . .	1	
22	97313-06045-00	BOLT (97021-06045-00) . . . . .	1	
23	90201-06067-00	WASHER, PLATE . . . . .	1	
24	95601-06100-00	NUT, U . . . . .	1	

# CRANKCASE

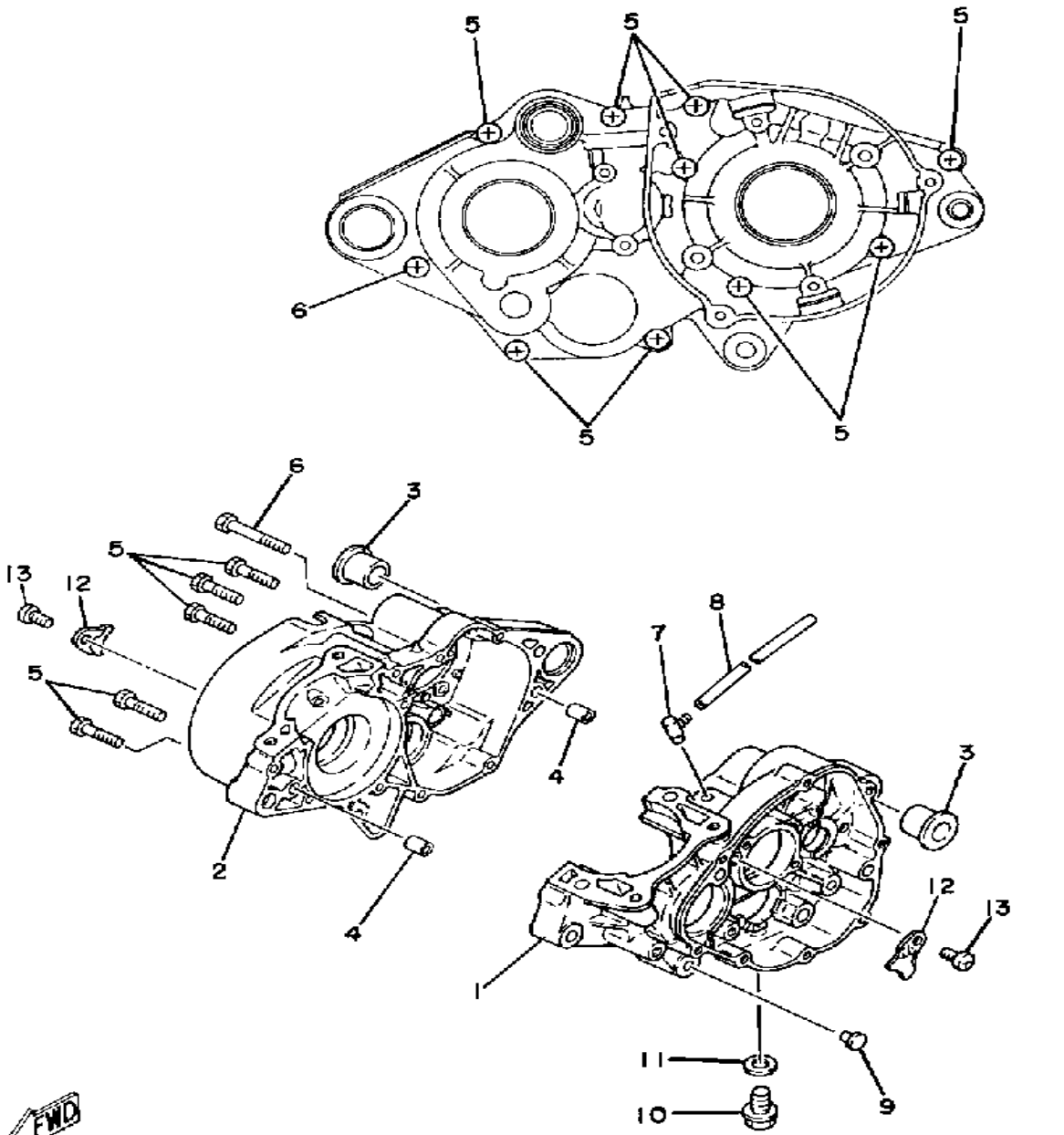

Ref. No.	Part Number	Description	Qty	Remarks
1	(3R3-15111-02-00)	CRANKCASE 1	1	
2	3R3-15121-02-00	CRANKCASE 2 (3R3-15121-01)	1	
3	90387-16781-00	COLLAR	2	
4	99530-10014-00	PIN, DOWEL	2	
5	91316-06035-00	BOLT	9	
6	91316-06050-00	BOLT, SOCKET HEAD	1	
7	2N4-15371-00-00	BREATHER	1	
8	90445-07340-00	HOSE	1	
9	90338-07011-00	PLUG, SPEC'L SHAPE	1	
10	90340-12097-00	PLUG, STRAIGHT SCREW	1	
11	90430-12207-00	GASKET	1	
12	3R3-15128-01-00	HOLDER	2	
13	92501-08010-00	SCREW, PAN HEAD	2	

Oiling System	Premix 16:1 Using Yamalube R*
Lubricant: Temp. Above 5°C (40°F)	Yamalube R*
Temp. Below 15°C (60°F)	Yamalube R*

# CRANKCASE COVER

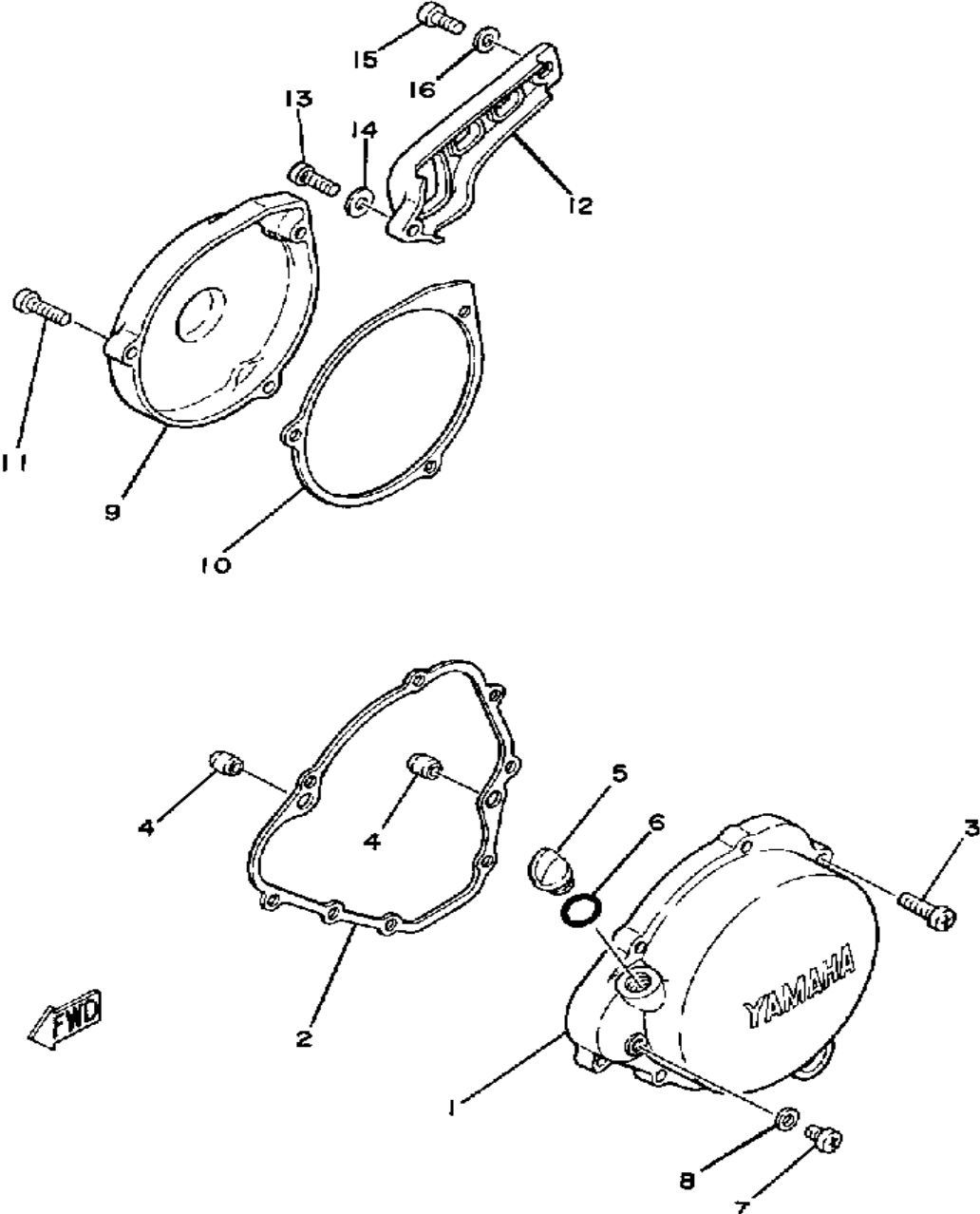

Ref. No.	Part Number	Description	Qty	Remarks
1	3R3-15411-01-00	COVER, CRANKCASE L	1	
2	3R3-15451-01-00	GASKET, CRCS COVER	1	
3	98506-06025-00	SCREW, PAN HEAD	8	
4	99530-10014-00	PIN, DOWEL	2	
5	1G8-15362-00-00	PLUG, OIL LEVEL	1	
6	93210-14104-00	O-RING	1	
7	98506-06008-00	SCREW, PAN HEAD (92506-06008-00)	1	
8	90430-06016-00	GASKET	1	
9	3R6-15421-00-00	COVER, CRANKCASE R	1	
10	3R6-15455-00-00	GASKET 1 (3R3-15455-00)	1	
11	98506-06025-00	SCREW, PAN HEAD	3	
12	55Y-15431-00-00	COVER, CRANKCASE 3	1	
13	98503-06014-00	SCREW, PAN HEAD (92502-06016)	1	
14	90201-06067-00	WASHER, PLATE	1	
15	98580-06020-00	SCREW	1	
16	92990-06200-00	WASHER	1	

Drain Plug 14 x 1.25: 2.0 m-kg

# KICK STARTER

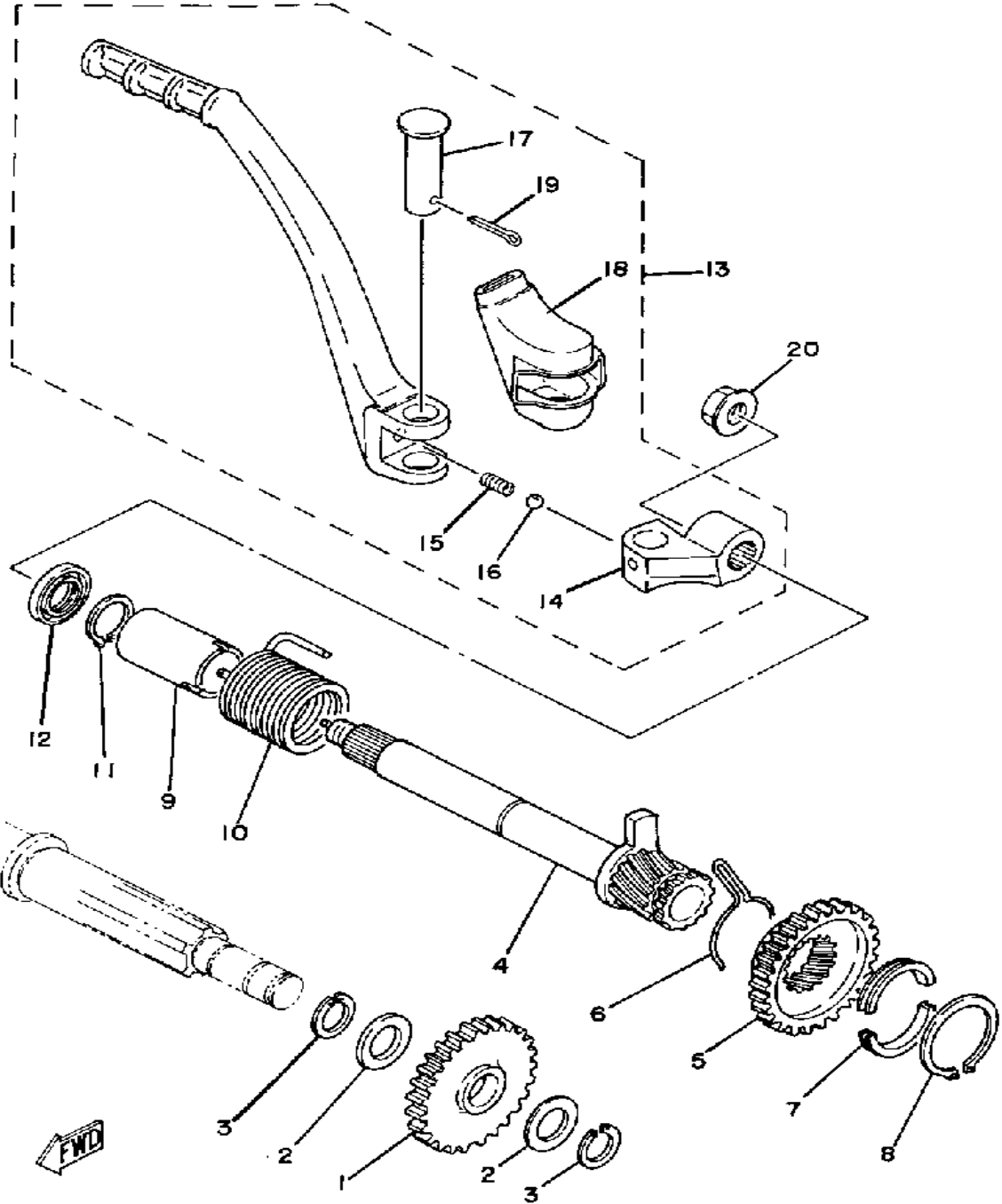

Ref. No.	Part Number	Description	Qty	Remarks
1	3R3-15651-01-00	GEAR, KICK IDLE .....	1	
2	137-17417-00-05	SHIM 1 (0.5T) .....	2	
3	93440-15012-00	CIRCLIP .....	2	
4	3R3-15660-00-00	KICK AXLE ASSEMBLY .....	1	
5	3R3-15641-00-00	GEAR, KICK .....	1	
6	90468-26048-00	CLIP .....	1	
7	248-15654-00-00	HOLDER, KICK GEAR .....	2	
8	99009-30400-00	CIRCLIP .....	1	
9	3R3-15666-00-00	SPACER .....	1	
10	90508-26427-00	SPRING, TORSION .....	1	
11	93410-17037-00	CIRCLIP .....	1	
12	93101-17062-00	OIL SEAL .....	1	
13	3R3-15620-00-00	KICK CRANK ASSEMBLY .....	1	
14	3R3-15621-01-00	. BOSS, KICK CRANK .....	1	
15	90501-12081-00	. SPRING, COMPRESSION .....	1	
16	93507-32031-00	. BALL .....	1	
17	91702-12040-00	. PIN, CLEVIS .....	1	
18	3R3-15618-01-00	. COVER, KICK LEVER .....	1	
19	91401-40020-00	. PIN, COTTER .....	1	
20	95701-10500-00	NUT, FLANGE (95702-10500) ..	1	

# CLUTCH

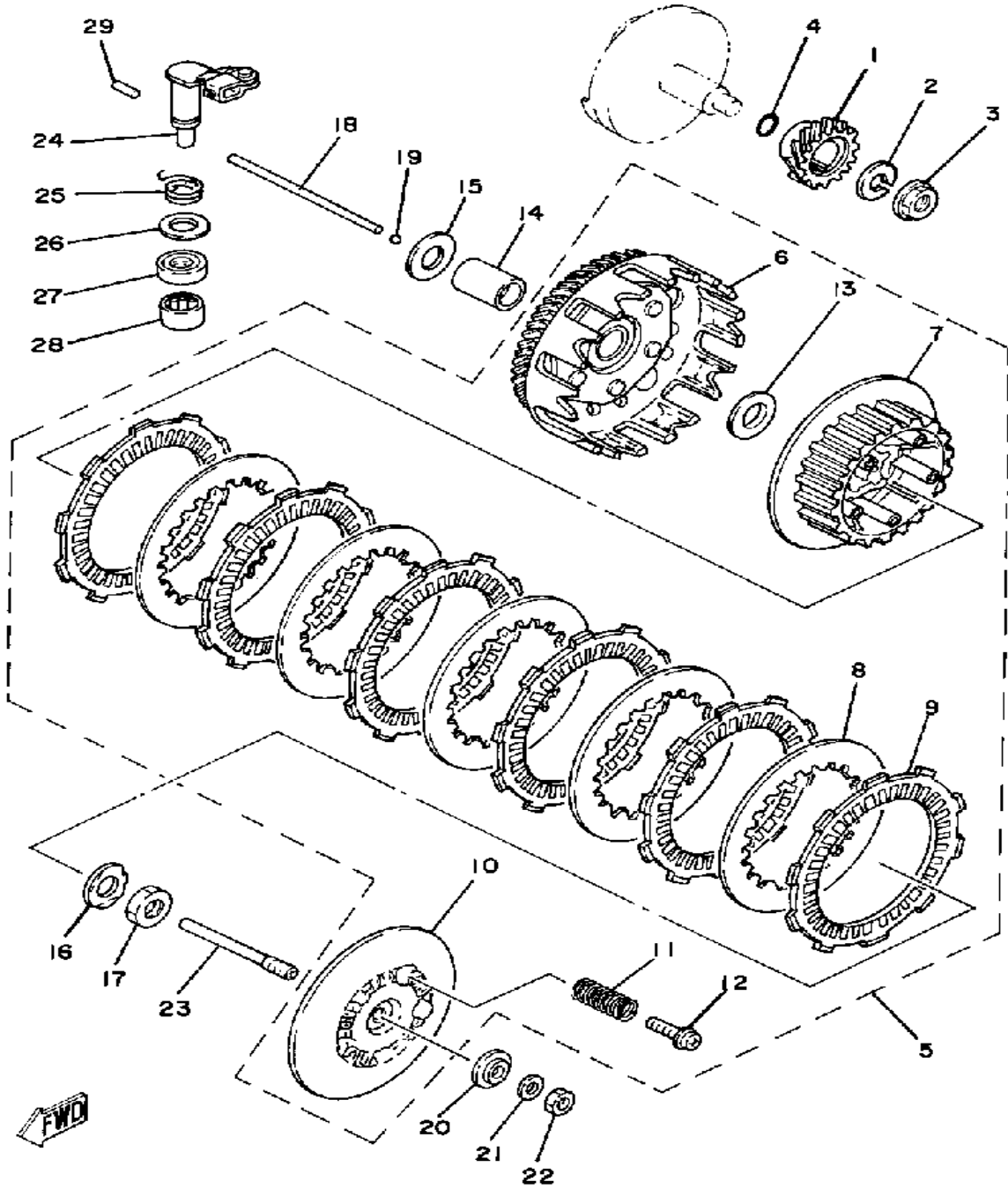

Ref. No.	Part Number	Description	Qty	Remarks
1	3R6-16111-00-00	GEAR, PRI DRIVE	1	
2	90204-12007-00	WASHER, SPRING	1	
3	90179-12335-00	NUT	1	
4	93210-20027-00	O-RING	1	
5	(3R6-16300-00-00)	CLUTCH ASSEMBLY	1	
6	3R6-16150-00-00	. PRI DRVN GEARCOMP. (52T)	1	
7	1G8-16371-00-00	. BOSS, CLUTCH	1	
8	137-16325-70-00	. PLATE, CLUTCH 2	5	
9	537-16321-00-00	. PLATE, FRICTION	6	
10	1W1-16351-00-00	. PLATE, PRESSURE 1	1	
11	90501-20361-00	. SPRING, COMPRESSION	5	
12	90159-05011-00	. SCREW, WITH WASHER	5	
13	90201-174E1-00	. WASHER, PLATE	1	
14	90560-17190-00	SPACER	1	
15	90201-174E1-00	WASHER, PLATE	1	
16	90215-14204-00	WASHER, LOCK	1	
17	90170-14171-00	NUT	1	
18	2X3-16357-00-00	ROD, PUSH 2	1	
19	93503-16010-00	BALL	1	
20	30X-16358-00-00	PLATE, PUSH	1	
21	92990-06200-00	WASHER	1	
22	95380-06600-00	NUT	1	
23	1W1-16356-02-00	ROD, PUSH 1	1	
24	3R3-16380-02-00	PUSH LEVER ASSEMBLY	1	
25	90508-14426-00	SPRING, TORSION	1	
26	90201-14217-00	WASHER, PLATE	1	
27	93104-14059-00	OIL SEAL, SO-TYPE	1	
28	93315-21429-00	BEARING	1	
29	93604-16092-00	PIN, DOWEL	1	

Clutch Nut 14 x 1.0: 6.0 m-kg (With Lock Washer)

# TRANSMISSION

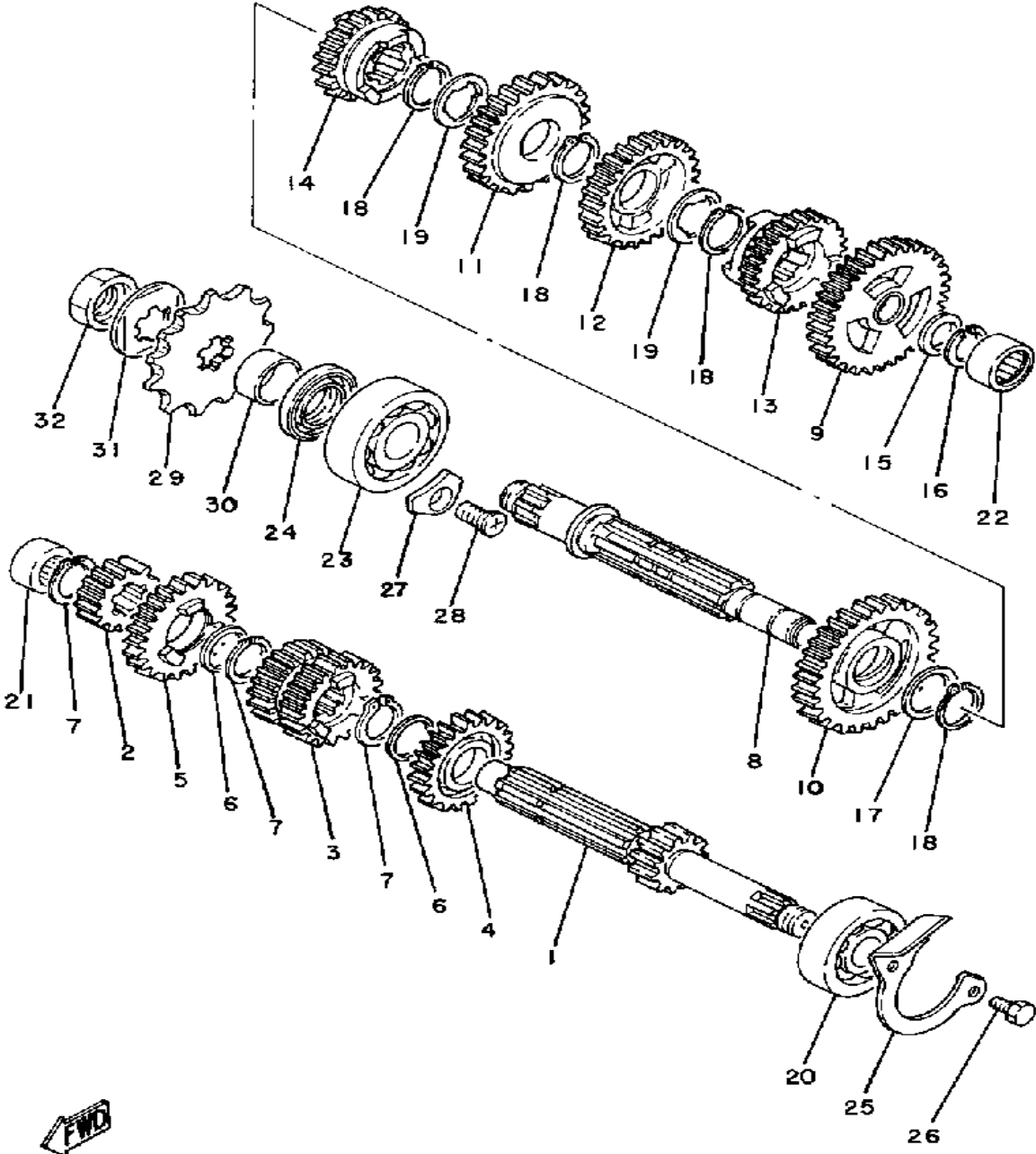

Ref. No.	Part Number	Description	Qty	Remarks
1	3R6-17411-00-00	AXLE, MAIN	1	
2	3R6-17121-00-00	GEAR, 2ND PINION	1	
3	3R6-17131-00-00	GEAR, 3RD PINION	1	
4	3R6-17151-00-00	GEAR, 5TH PINION	1	
5	3R6-17161-00-00	GEAR, 6TH PINION	1	
6	90201-20266-00	WASHER, PLATE (1.0T)	2	
7	93410-20038-00	CIRCLIP	3	
8	3R3-17421-00-00	AXLE, DRIVE	1	
9	3R6-17211-00-00	GEAR, 1ST WHEEL	1	
10	3R6-17221-00-00	GEAR, 2ND WHEEL	1	
11	3R3-17231-01-00	GEAR, 3RD WHEEL (24T)	1	
12	3R6-17241-00-00	GEAR, 4TH WHEEL	1	
13	3R6-17251-00-00	GEAR, 5TH WHEEL	1	
14	3R6-17261-00-00	GEAR, 6TH WHEEL	1	
15	90201-15701-00	WASHER, PLATE (1.0T)	1	
16	93440-15012-00	CIRCLIP	1	
17	90201-22555-00	WASHER, PLATE	1	
18	93410-22039-00	CIRCLIP	4	
19	90209-18135-00	WASHER	2	
20	93306-30309-00	BEARING	1	
21	93311-41530-00	BEARING	1	
22	93311-31567-00	BEARING, CYLINDRICAL	1	
23	93306-30411-00	BEARING (B6304)	1	
24	93102-26042-00	OIL SEAL	1	
25	3R3-17471-00-00	PLATE, COVER	1	
26	97013-06012-00	BOLT	2	
27	2K7-15383-00-00	PLATE, BEARING COVER	1	
28	98603-06012-00	SCREW, OVAL HEAD (92701-06012)	1	

Lubricant: Temp. Above 5°C (40°F)	Yamalube R*
Temp. Below 15°C (60°F)	Yamalube R*
Oiling System	Premix 16:1 Using Yamalube R*

CONTINUED ON NEXT FRAME ►

# TRANSMISSION

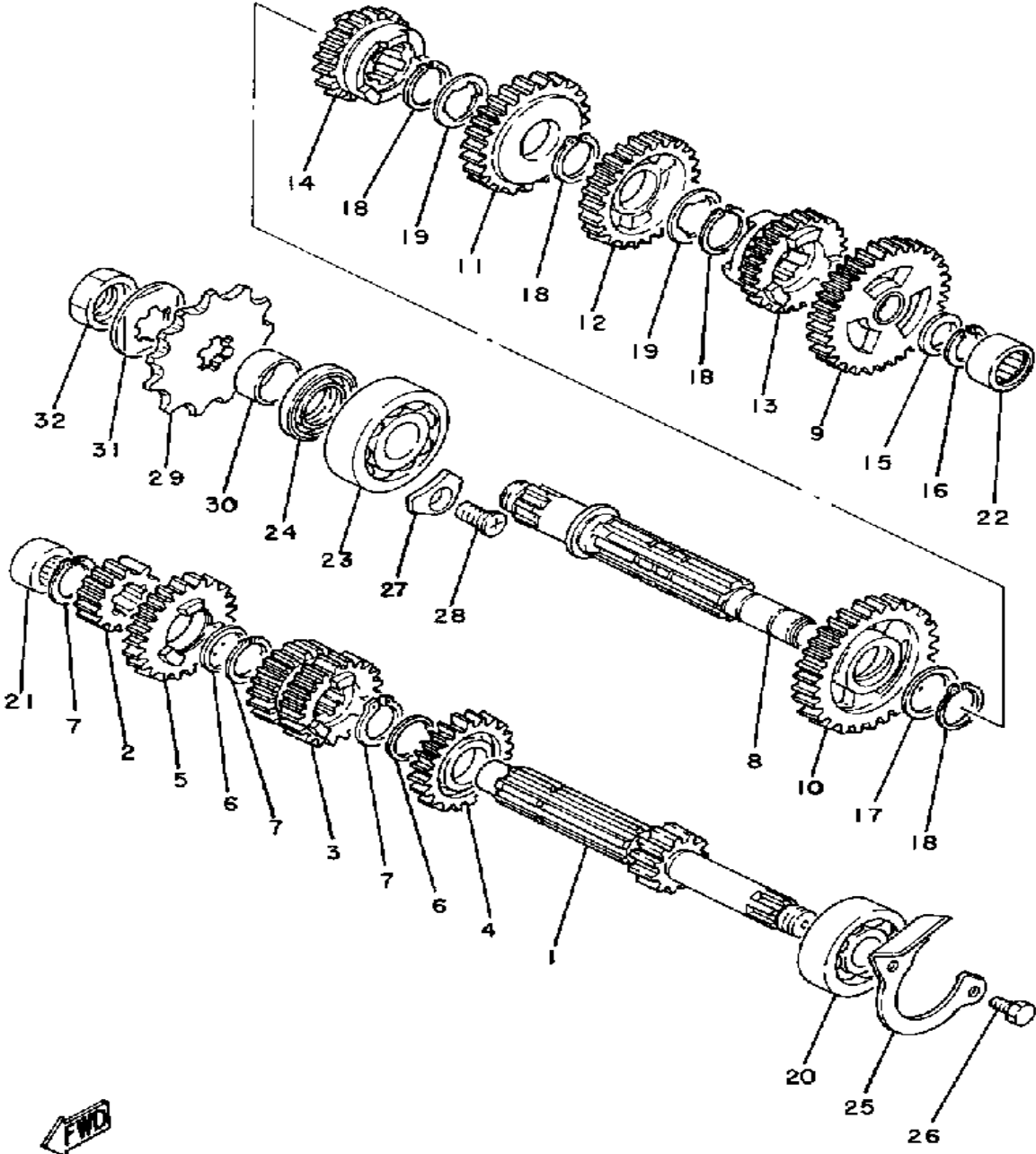

Ref. No.	Part Number	Description	Qty	Remarks
29	93832-11007-00	SPROCKET, DRIVE 11T	1	U.R.
	93832-12014-00	SPROCKET, DRIVE	1	U.R.
	93832-13027-00	SPROCKET, DRIVE	1	U.R.
30	90387-202A0-00	COLLAR	1	
31	90215-16127-00	WASHER, LOCK	1	
32	90179-16226-00	NUT	1	

Lubricant: Temp. Above 5°C (40°F)	Yamalube R*
Temp. Below 15°C (60°F)	Yamalube R*
Oiling System	Premix 16:1 Using Yamalube R*

# SHIFT CAM-FORK

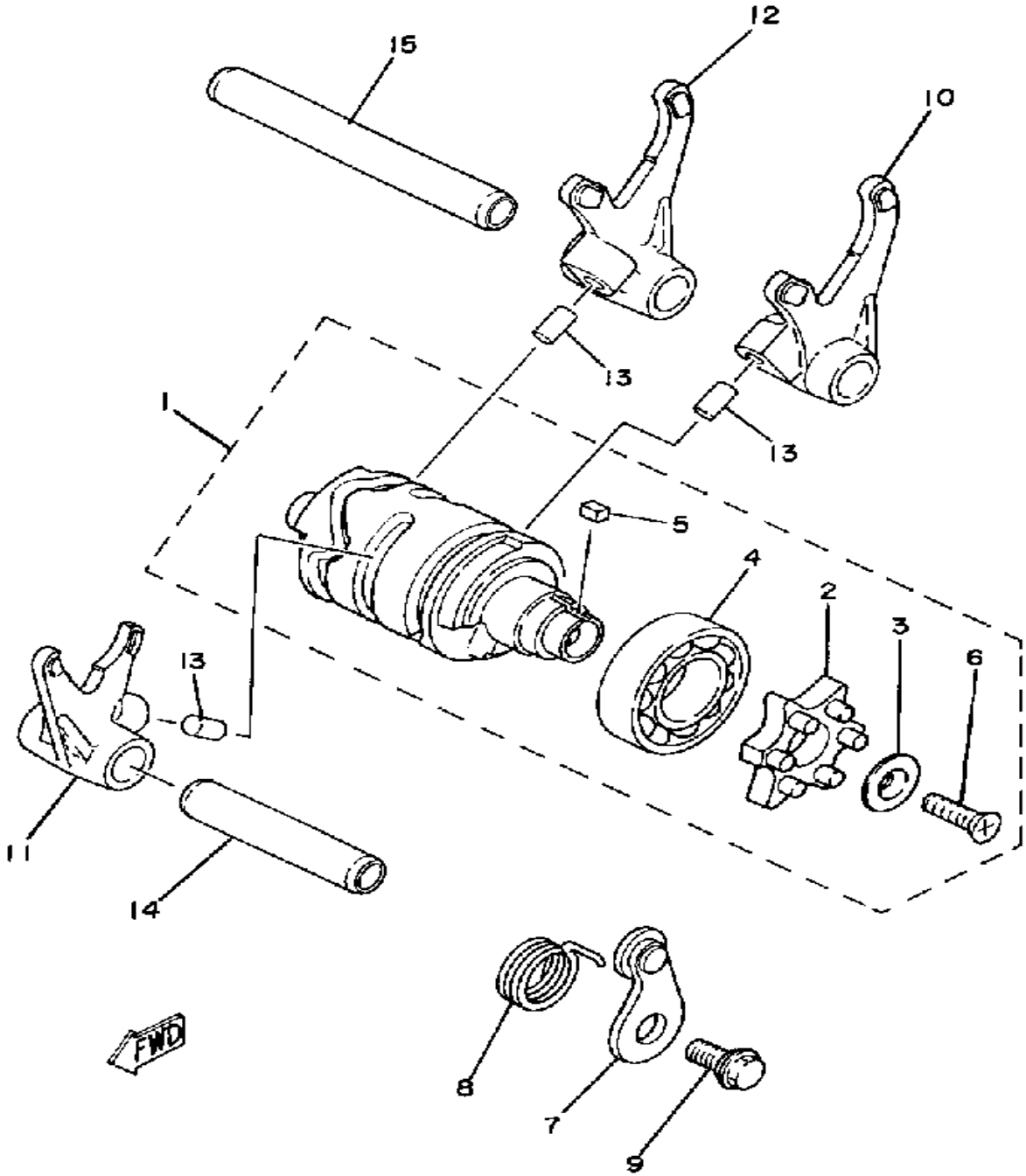

Ref. No.	Part Number	Description	Qty	Remarks
1	24X-18540-00-00	SHIFT CAM ASSEMBLY	1	
2	3R4-18185-00-00	. SEGMENT	1	
3	3R4-18561-00-00	. PLATE, SIDE 1	1	
4	93306-00435-00	. BEARING	1	
5	90282-04036-00	. KEY, STRAIGHT	1	
6	98701-05016-00	. SCREW, FLAT HEAD	1	
7	3R3-18140-00-00	STOPPER LEVER ASSEMBLY	1	
8	90508-26435-00	SPRING, TORSION	1	
9	50W-21631-00-00	BOLT 1	1	
10	3R3-18511-00-00	FORK, SHIFT 1	1	
11	3R3-18512-00-00	FORK, SHIFT 2	1	
12	3R3-18513-00-00	FORK, SHIFT 3	1	
13	90250-06013-00	PIN, STRAIGHT	3	
14	5X5-18531-01-00	BAR, SHIFT FORK GUIDE 1	1	
15	5X5-18535-01-00	BAR, SHIF FRK GDE 2	1	



# SHIFT SHAFT-PEDAL

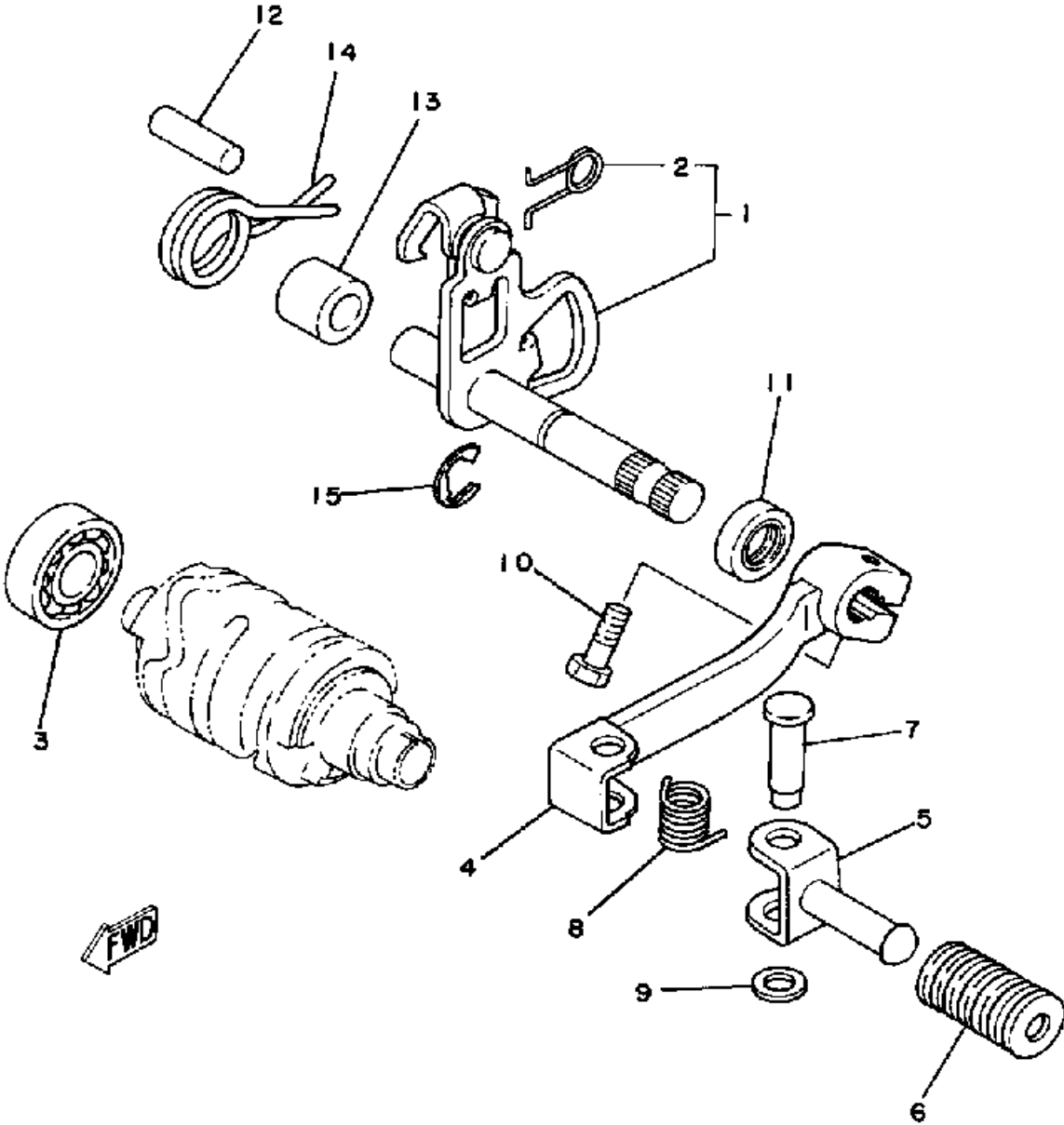

Ref. No.	Part Number	Description	Qty	Remarks
1	24X-18101-01-00	SHIFT SHAFT ASSEMBLY. 1	1	
2	(90508-09420-00)	SPRING, TORSION	1	
3	93306-20110-00	BEARING (B6201)	1	
4	5X6-18110-00-00	PEDAL, SHIFT	1	
5	3R8-18162-00-00	PEDAL, SHIFT	1	
6	1W6-18113-00-00	COVER, SHIFT PEDAL	1	
7	90243-08019-00	PIN (90243-08017)	1	
8	90508-20415-00	SPRING, TORSION	1	
9	90201-06042-00	WASHER, PLATE	1	
10	97011-06025-00	BOLT (97001-06025)	1	
11	93101-12060-00	OIL SEAL	1	
12	93608-25150-00	PIN, DOWEL	1	
13	90560-11189-00	SPACER	1	
14	90508-32374-00	SPRING, TORSION	1	
15	99006-10600-00	CIRCLIP	1	

# FRAME

Ref. No.	Part Number	Description	Qty	Remarks
1	(3R6-21110-02-33)	FRAME .....	1	YAMAHA BLACK
2	90339-13005-00	PLUG .....	2	
3	2K6-22178-00-00	TENSIONER .....	1	
4	3R3-2148A-00-00	SHAFT .....	1	
5	90201-13202-00	WASHER, PLATE .....	2	
6	97313-08050-00	BOLT, HEXAGON (90101-08125) .....	1	
7	95712-08300-00	NUT, LOCK .....	1	
8	92990-08200-00	WASHER, PLAIN .....	2	
9	3R3-21415-00-00	BRACKET, FRT UPR 1 .....	2	
10	95811-08075-00	BOLT, FLANGE .....	3	
11	95811-08160-00	BOLT, FLANGE .....	1	
12	90214-09019-00	WASHER, CLAW .....	1	
13	92990-08200-00	WASHER, PLAIN .....	4	
14	90185-08089-00	NUT, SELF-LOCKING .....	4	
15	(3R6-21471-00-00)	PROTECTOR, ENGINE .....	1	
16	2J5-21732-00-00	SEAL 1 .....	2	
17	97011-08016-00	BOLT .....	3	
18	92990-08100-00	WASHER .....	3	
19	92901-08600-00	WASHER .....	3	
20	(3R4-2139W-00-00)	COVER .....	1	

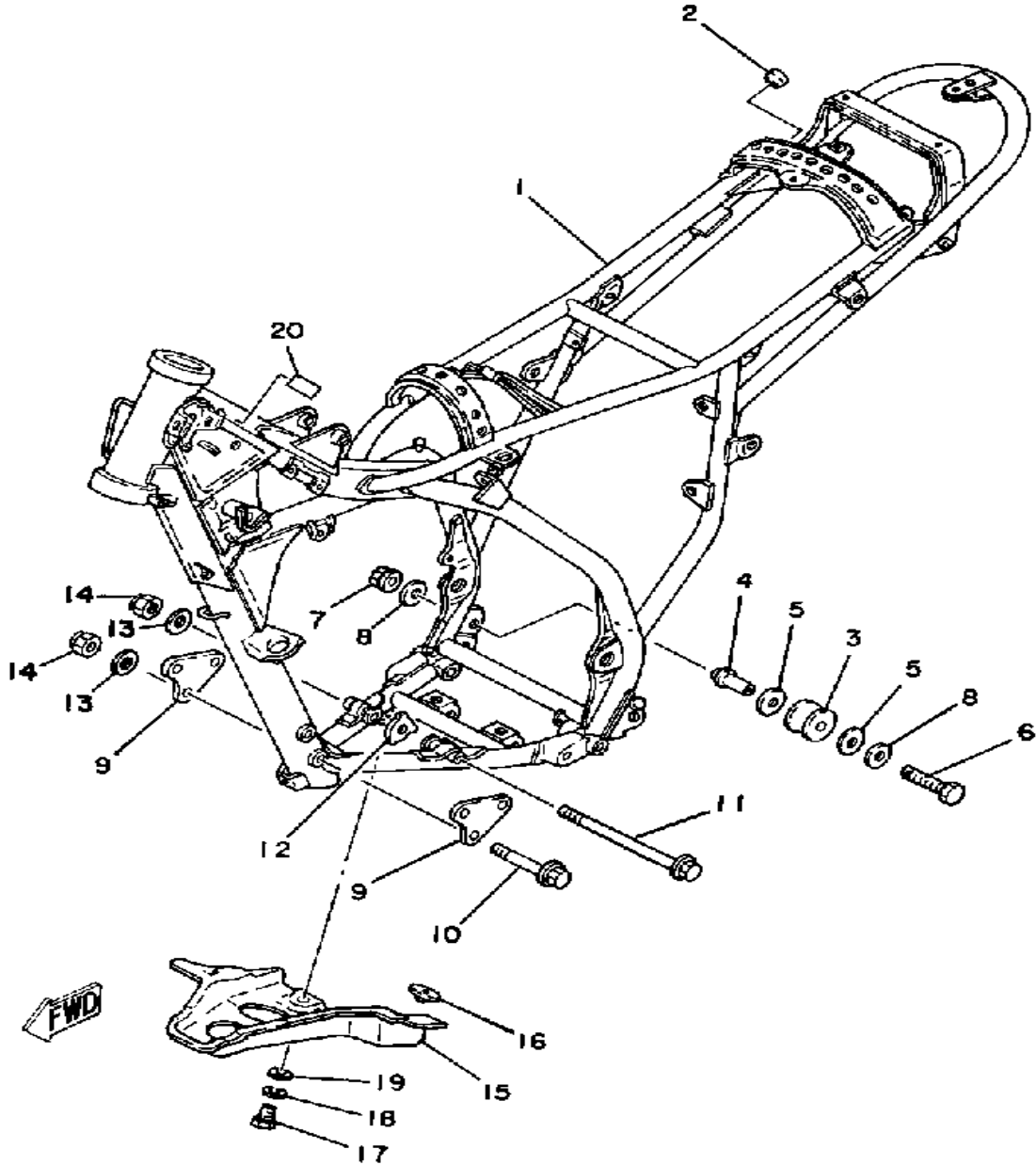

Initial Engine Number / Frame Number	3R6-020101 / 3R6-020101
Engine Mounting Bolts: Engine Front.	8 x 1.5: 3.0 m-kg
Engine Center	8 x 1.5: 3.0 m-kg

# FRONT FENDER-REAR FENDER

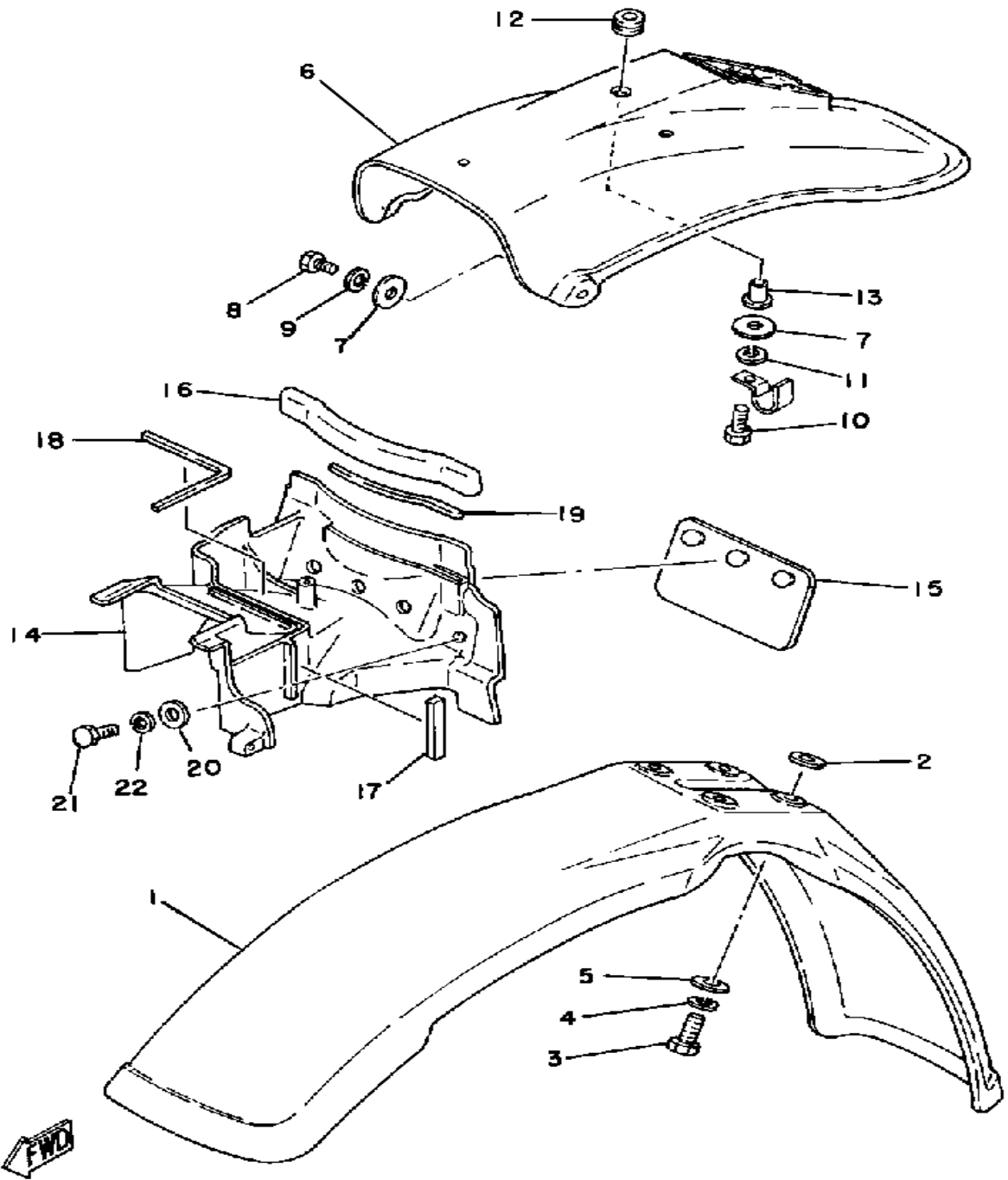

Ref. No.	Part Number	Description	Qty	Remarks
1	5X6-21511-11-00	FENDER, FRONT	1	CLEAN WHITE
2	90201-06067-00	WASHER, PLATE	4	
3	97023-06020-00	BOLT (3XF)	4	
4	92995-06100-00	WASHER, SPRING	4	
5	90209-06187-00	WASHER	4	
6	3R6-21610-01-00	FENDER, REAR	1	CLEAN WHITE
7	90201-06067-00	WASHER, PLATE	4	
8	97301-06014-00	BOLT, HEXAGON	2	
9	92995-06100-00	WASHER, SPRING	2	
10	97011-06025-00	BOLT (97001-06025)	1	
11	92995-06100-00	WASHER, SPRING	1	
12	90480-14198-00	GROMMET	1	
13	90387-06388-00	COLLAR	1	
14	(3R6-21629-00-00)	GUARD, MUD	1	
15	1M1-21621-00-00	FLAP	1	
16	565-21746-00-00	DAMPER	1	
17	(3R6-21638-00-00)	DAMPER 1	1	
18	(3R6-21639-00-00)	DAMPER 2	1	
19	1X2-28372-00-00	DAMPER (55X-21541-00)	1	
20	90201-06067-00	WASHER, PLATE	2	
21	97301-06014-00	BOLT, HEXAGON	2	
22	92995-06100-00	WASHER, SPRING	2	

# SIDE COVER

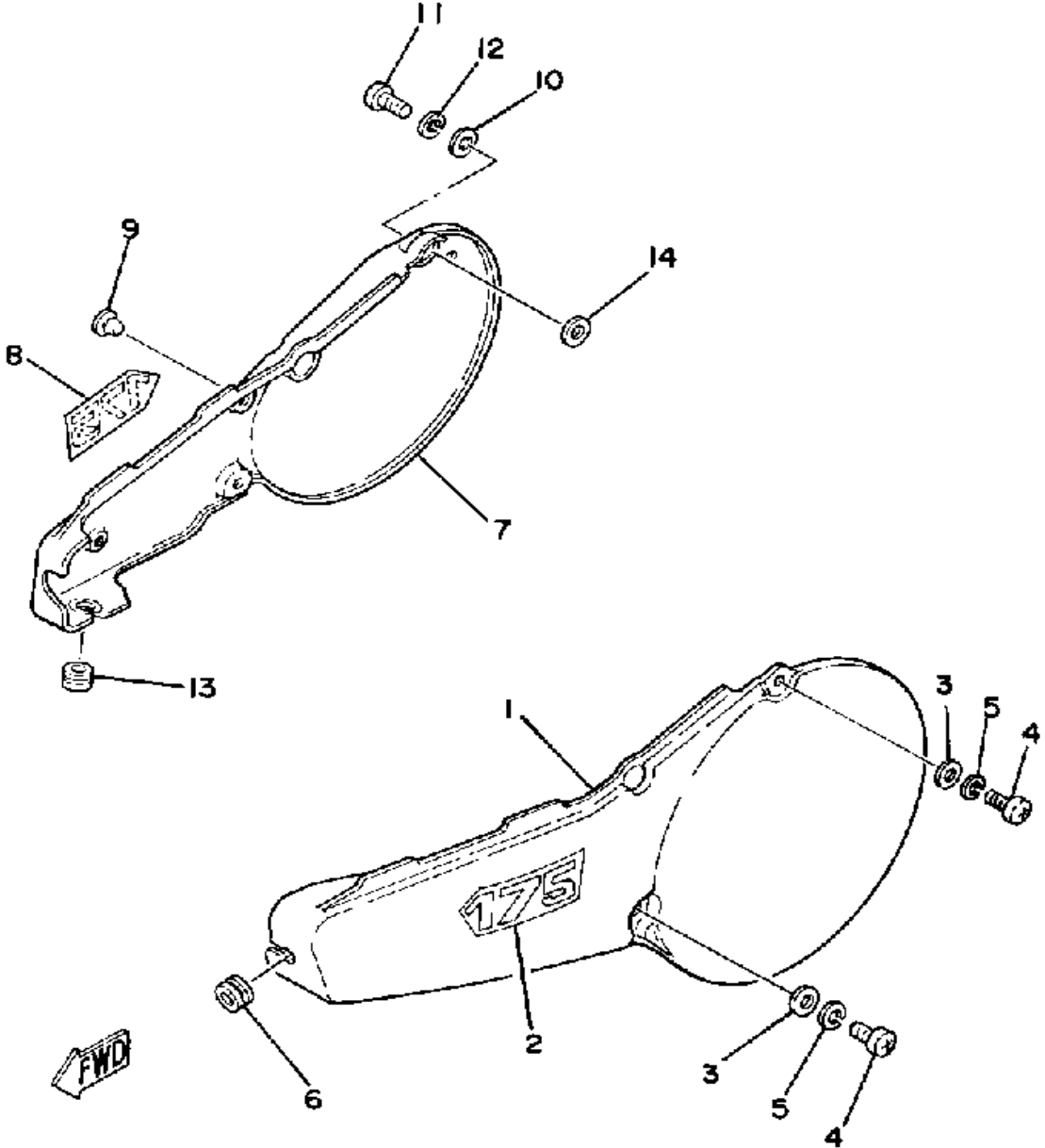

Ref. No.	Part Number	Description	Qty	Remarks
1	3R3-21711-10-26	COVER, SIDE 1 .....	1	COMP. YELLOW/6WHITE
2	3R6-21737-10-00	EMBLEM .....	1	
3	90201-06067-00	WASHER, PLATE .....	2	
4	98503-06014-00	SCREW, PAN HEAD (92502-06016) .....	2	
5	92995-06100-00	WASHER, SPRING .....	2	
6	90480-12053-00	GROMMET .....	1	
7	3R6-21721-10-26	COVER, SIDE 2 .....	1	COMP. YELLOW/6WHITE
8	3R6-21737-10-00	EMBLEM .....	1	
9	22W-24181-00-00	DAMPER, LOCATING 1 .....	3	
10	90201-06067-00	WASHER, PLATE .....	2	
11	98503-06014-00	SCREW, PAN HEAD (92502-06016) .....	2	
12	92995-06100-00	WASHER, SPRING .....	2	
13	90480-12053-00	GROMMET .....	1	
14	92990-08200-00	WASHER, PLAIN .....	1	

# REAR ARM

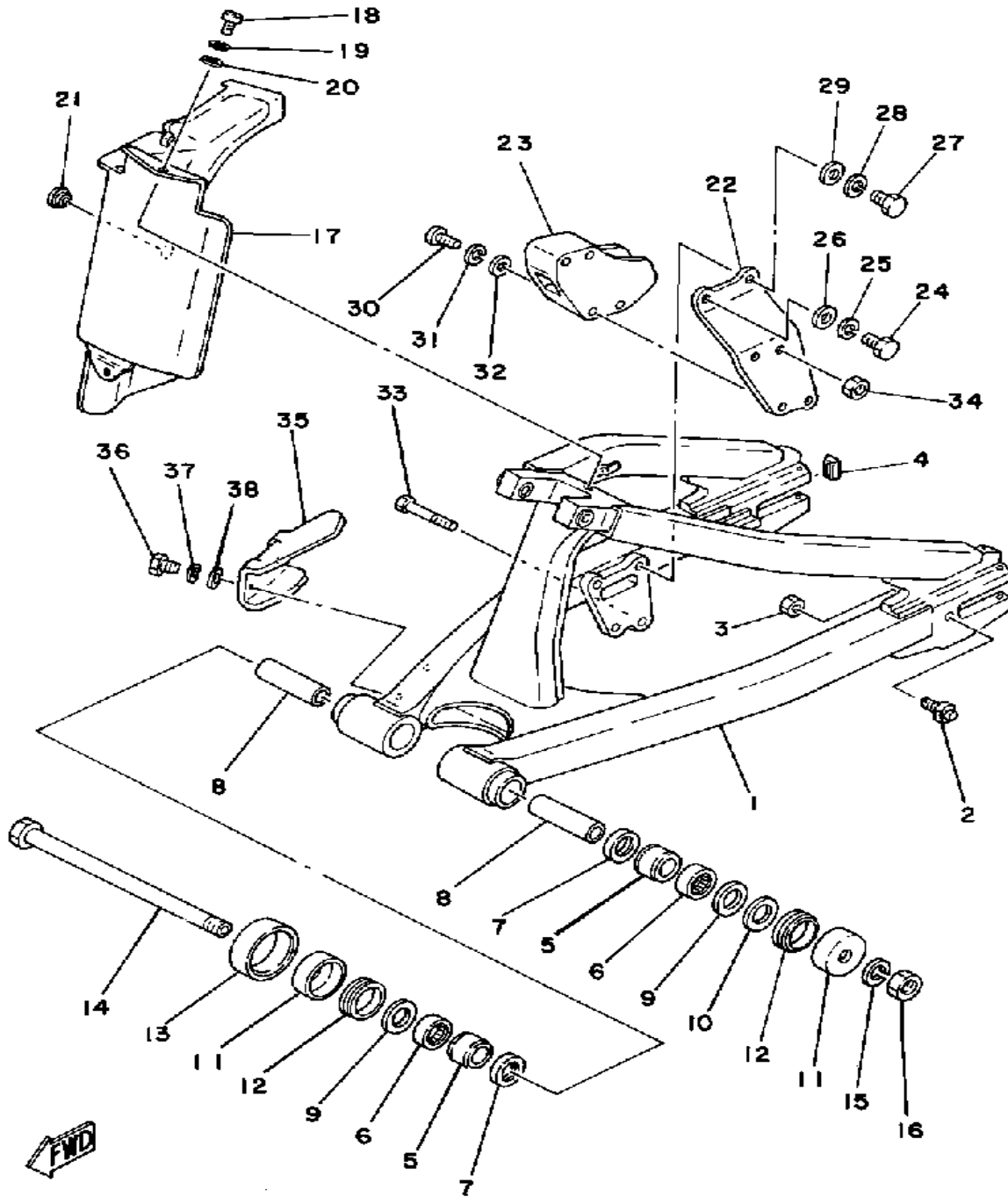

Ref. No.	Part Number	Description	Qty	Remarks
1	(3R6-22110-00-35)	REAR ARM .....	1	SILVER
2	90109-08569-00	BOLT .....	2	
3	95701-08500-00	NUT, FLANGE .....	2	
4	(90338-22103-00)	PLUG, SPEC'L SHAPE .....	2	
5	90386-22097-00	BUSH, SPEC'L NYLON .....	2	
6	93317-22214-00	BEARING, CYLINDER.# 7 .....	2	
7	93109-22018-00	OIL SEAL, SDO-TYPE .....	2	
8	90380-16077-00	BUSH, SOLID .....	2	
9	90201-22680-00	WASHER, PLATE .....	2	
10	240-22127-00-00	SHIM .....	1	U.N.
11	2K6-22128-01-00	COVER, THRUST 1 .....	2	
12	93108-35004-00	OIL SEAL (35-41-8) .....	2	
13	431-22151-03-00	SEAL, GUARD .....	1	
14	1W4-22141-00-00	SHAFT, PIVOT .....	1	
15	92901-16100-00	WASHER, SPRING .....	1	
16	90170-16111-00	NUT, HEXAGON .....	1	
17	3R6-22311-00-00	CASE, CHAIN .....	1	BLACK
18	98580-06012-00	SCREW, PAN HEAD .....	2	
19	92995-06100-00	WASHER, SPRING .....	2	
20	92990-06200-00	WASHER .....	2	
21	90560-08066-00	SPACER .....	1	
22	3R3-22179-00-00	ARM, TENSIONER .....	1	
23	3R3-22199-00-00	SUPPORT, CHAIN .....	1	
24	97313-08020-00	BOLT, HEXAGON .....	1	
25	92990-08100-00	WASHER .....	1	
26	92990-08200-00	WASHER, PLAIN .....	1	
27	97313-08018-00	BOLT, HEXAGON (97301-08016) .....	1	
28	92990-08100-00	WASHER .....	1	
29	92901-08600-00	WASHER .....	1	

CONTINUED ON NEXT FRAME ►

# REAR ARM

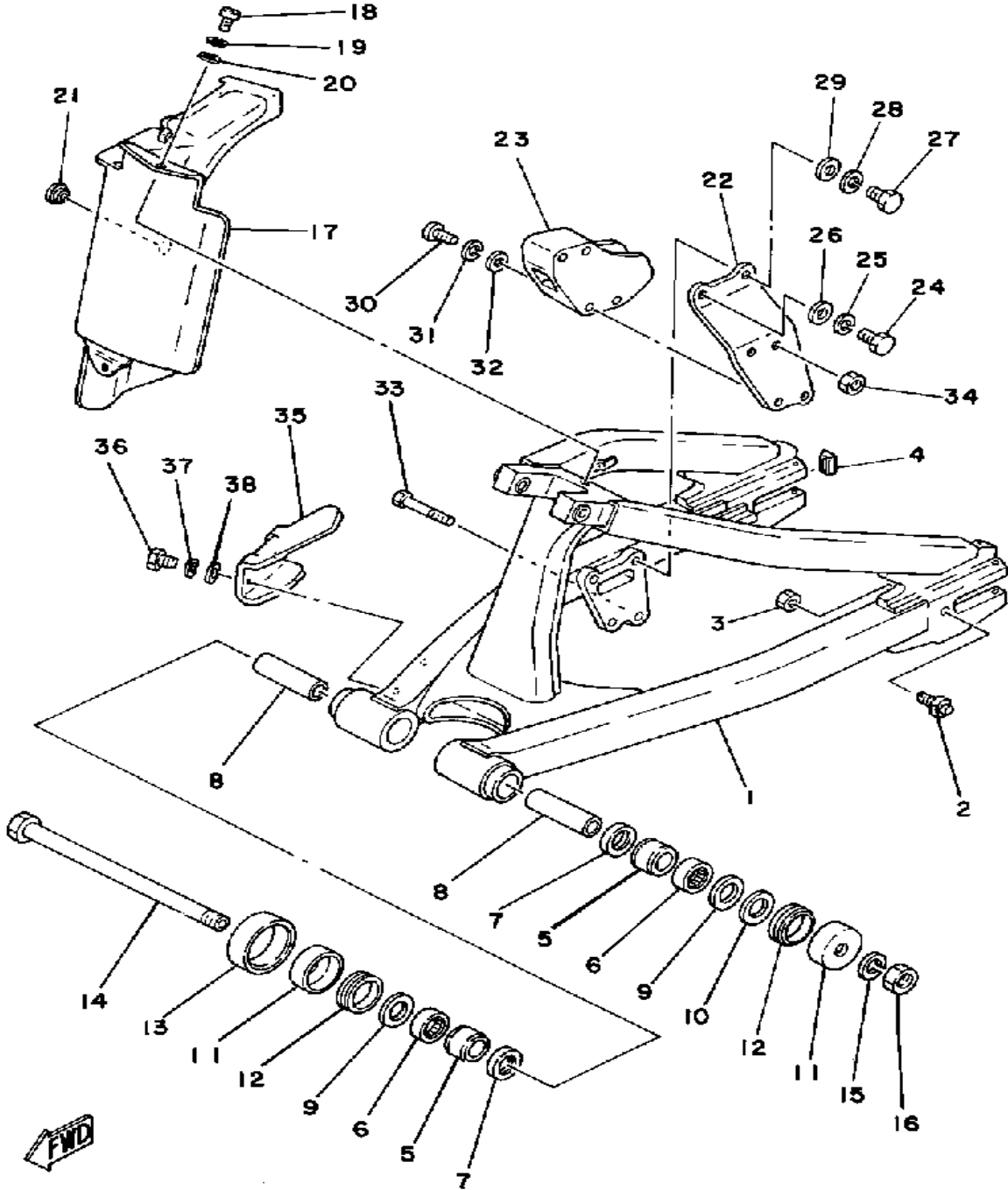

Ref. No.	Part Number	Description	Qty	Remarks
30	98580-06020-00	SCREW	2	
31	92995-06100-00	WASHER, SPRING	2	
32	92901-06600-00	WASHER	2	
33	97313-06055-00	BOLT, HEXAGON (97322-06055)	2	
34	95601-06100-00	NUT, U	2	
35	3R3-22147-00-00	PROTECTOR, CHAIN	1	
36	97313-05012-00	BOLT, HEXAGON	2	
37	92990-05100-00	WASHER, SPRING	2	
38	92990-05200-00	WASHER, PLAIN	2	

# REAR SUSPENSION

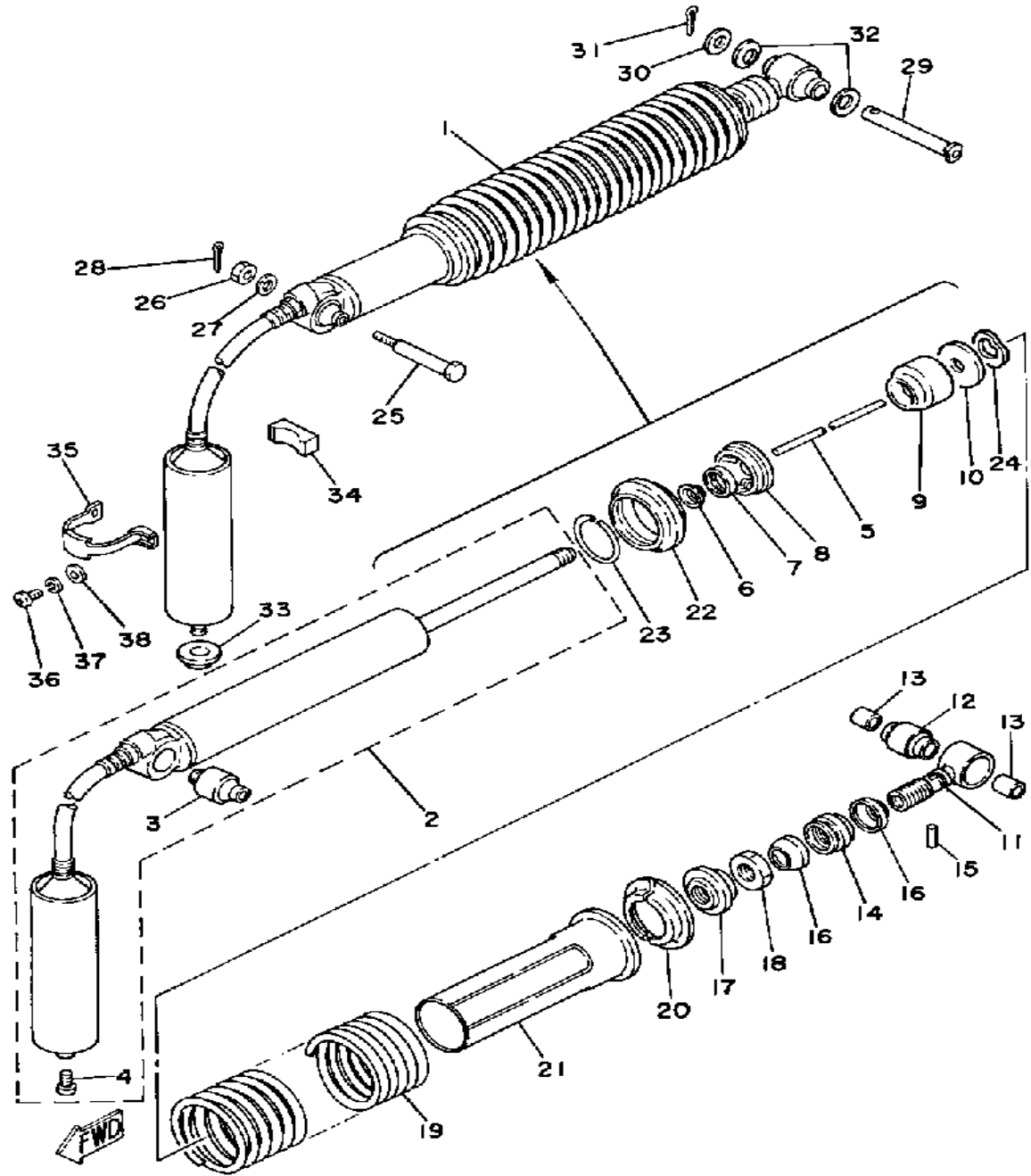

Monoshock: Oil Type / Qty	Not Rebuildable
Gas Pressure	15 kg/cm <sup>2</sup> (213.4 psi)

Ref. No.	Part Number	Description	Qty	Remarks
1	(3R6-22210-10-00)	SHK/ABS ASSEMBLY, REAR	1	
2	(3R6-22401-10-00)	DAMPER SUB-ASSEMBLY.	1	
3	1YW-22216-00-00	. . BUSH, RR SHOCK ABS	1	
4	98511-04006-00	. . SCREW, PAN HEAD (98501-04005)	1	
5	(3R4-22489-00-00)	ROD, PUSH	1	
6	23X-22475-00-00	. SEAL, DUST	1	
7	23X-22475-00-00	. SEAL, DUST	1	
8	26A-22472-00-00	. CAP, CASE	1	
9	(1W1-22493-00-00)	BUMP, STOP	1	
10	3R4-22228-00-00	. SUPPORT, BUMP STOP	1	
11	3R4-22409-00-00	. UPPER BRKT SUB ASSEMBLY	1	
12	3R4-22226-00-00	. BUSH, SHOCK ABS LWR	1	
13	90380-12051-00	. BUSH, SOLID	2	
14	5X3-22497-00-00	. NUT, ADJUSTING	1	
15	93604-26132-00	. PIN, DOWEL	1	
16	3R4-22221-01-00	. COVER	2	
17	3R4-22213-00-00	. SEAT, SPRING UPPER	1	
18	90170-20320-00	. NUT	1	
19	(3R6-22212-00-00)	SPRING	1	
	(3R6-22212-10-00)	SPRING, ALT	1	U.R.
	(3R6-22212-20-00)	SPRING, ALT	1	U.R.
20	3R4-22214-01-00	. GUIDE, SPRING 1 (3R4-22214-00)	2	
21	3R4-22224-00-00	. GUIDE, SPRING 2	1	
22	3R4-22223-00-00	. SEAT, SPRING LOWER	1	
23	93440-50078-00	. CIRCLIP, OUTER	1	
24	90206-14067-00	. WASHER, WAVE	1	
25	90109-10550-00	BOLT (90109-10453-00)	1	

CONTINUED ON NEXT FRAME ➤

# REAR SUSPENSION

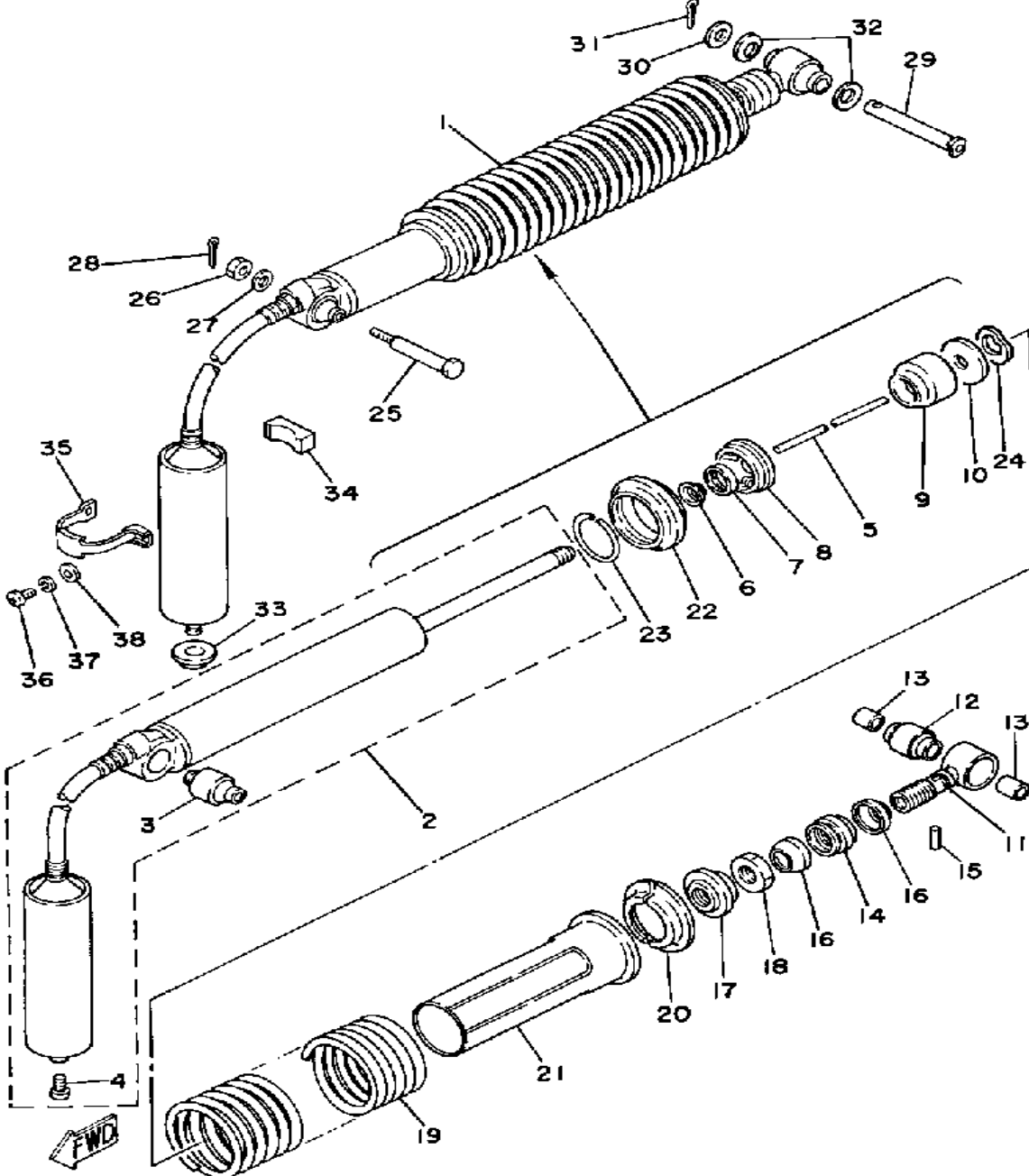

Ref. No.	Part Number	Description	Qty	Remarks
26	95303-10700-00	NUT .....	1	
27	92990-10600-00	WASHER, PLATE .....	1	
28	91490-20025-00	PIN, SPLIT .....	1	
29	90240-12074-00	PIN, CLEVIS .....	1	
30	92990-12600-00	WASHER, PLATE .....	1	
31	91401-30030-00	PIN, COTTER .....	1	
32	1W1-22128-00-00	COVER, THRUST 1 .....	2	
33	90480-22263-00	GROMMET .....	1	
34	3R4-22261-00-00	DAMPER, SUB TANK .....	1	
35	3R3-22262-00-00	HOLDER, SUB TANK .....	1	
36	98503-06014-00	SCREW, PAN HEAD (92502-06016) .....	1	
37	92995-06100-00	WASHER, SPRING .....	1	
38	92901-06600-00	WASHER .....	1	

Monoshock: Oil Type / Qty	Not Rebuildable
Gas Pressure	15 kg/cm <sup>2</sup> (213.4 psi)



# STEERING

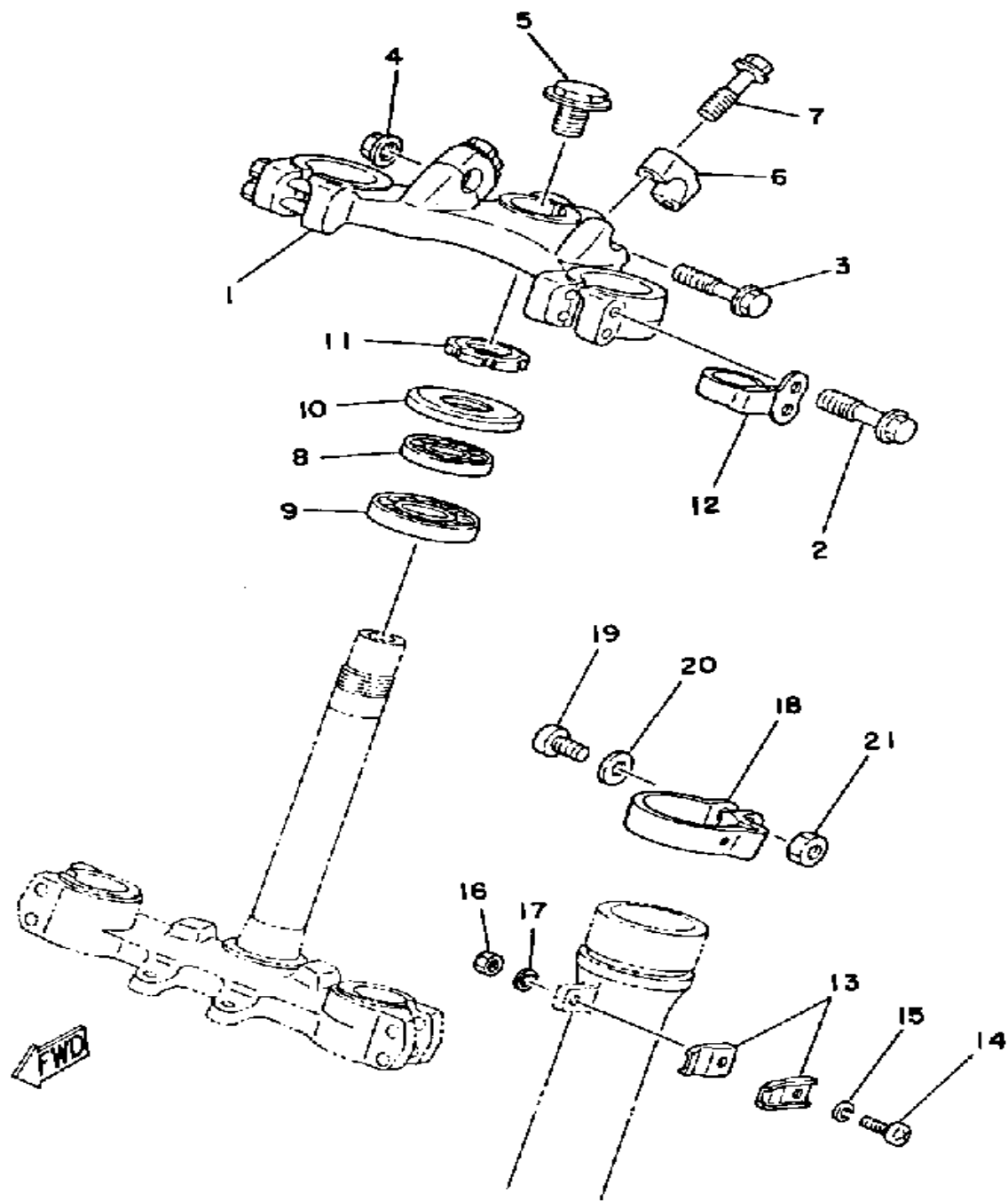

Ref. No.	Part Number	Description	Qty	Remarks
1	5X3-23435-01-98	CROWN, HANDLE .....	1	LOW GLOSS BLK
2	90105-08091-00	BOLT, WASHER BASED .....	4	
3	95811-08055-00	BOLT, FLANGE .....	1	
4	95701-08500-00	NUT, FLANGE .....	1	
5	90105-14136-00	BOLT, WASHER BASED .....	1	
6	1E6-23441-00-00	HOLDER, HANDLE UPR .....	2	LOW GLOSS BLK
7	95811-08035-00	BOLT, FLANGE (95821-08035) .	4	
8	93332-00001-00	BEARING .....	1	
9	93332-00008-00	BEARING .....	1	
10	3HE-23416-00-00	COVER, BALL RACE 2 .....	1	
11	90179-25033-00	NUT .....	1	
12	3R4-23317-00-00	HOLDER, CABLE .....	1	
13	90462-14055-00	CLAMP .....	2	
14	98511-06025-00	SCREW PAN HEAD (92501-06025) .....	1	
15	92995-06100-00	WASHER, SPRING .....	1	
16	95380-06600-00	NUT .....	1	
17	92901-06600-00	WASHER .....	1	
18	1W2-23318-00-00	HOLDER, CABLE 1 .....	1	
19	98501-05018-00	SCREW, PAN HEAD .....	1	
20	92901-05600-00	WASHER, PLATE .....	1	
21	95380-05600-00	NUT .....	1	

# FRONT FORK

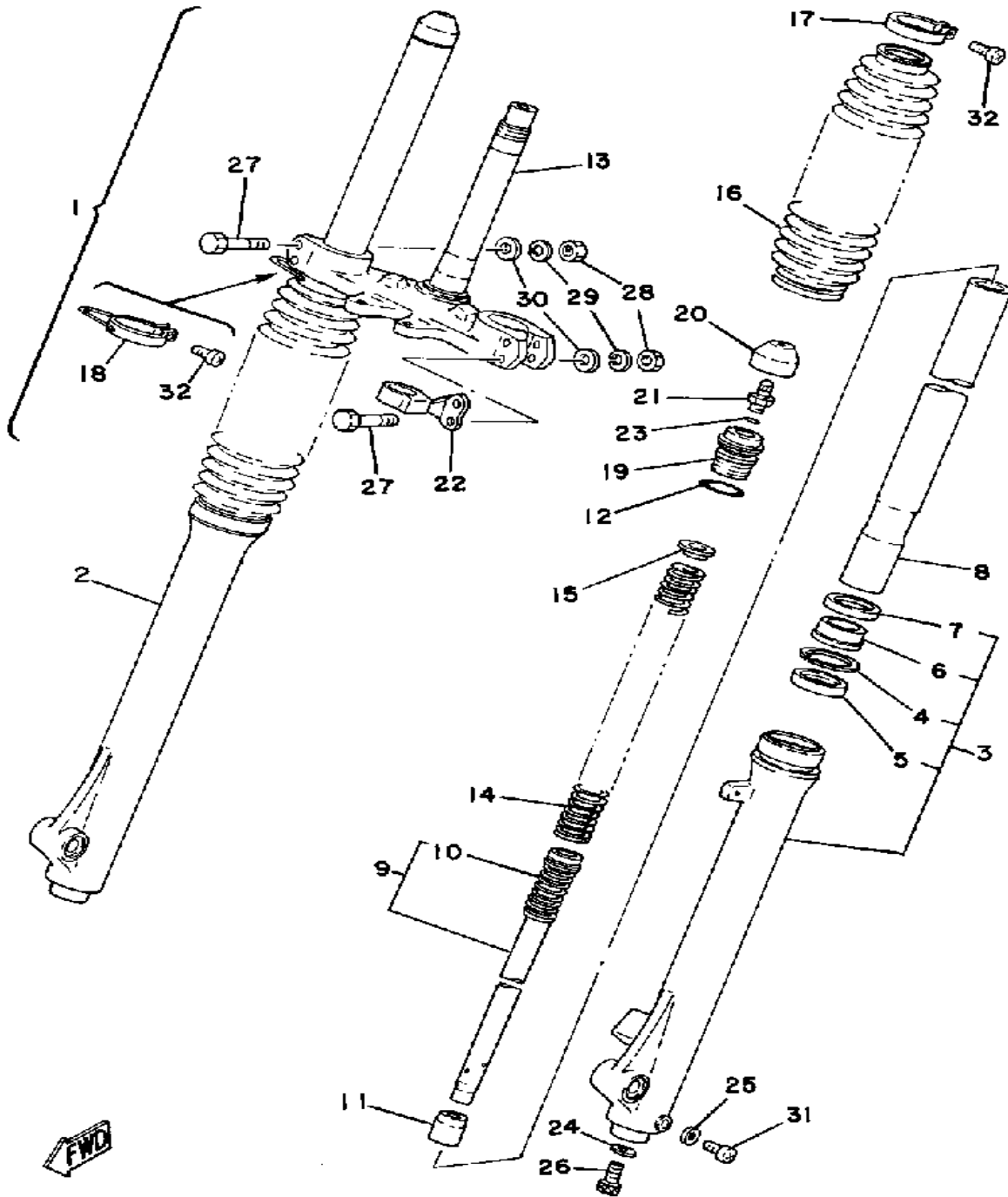

Ref. No.	Part Number	Description	Qty	Remarks
1	(3R6-23101-L0-00)	FRONT FORK ASSEMBLY	1	
2	(3R6-23136-L0-00)	TUBE, OUTER 2	1	
3	(3R6-23126-L0-00)	TUBE, OUTER 1	1	
4	4A1-23156-00-00	.. CLIP, OIL SEAL	2	
5	48Y-23145-00-00	.. OIL SEAL	2	
6	509-23144-L0-00	.. SEAL, DUST	2	
7	3R8-23148-L0-00	.. COVER, DUST SEAL	2	
8	(3R6-23110-L0-00)	INNER TUBE 1	2	
9	(3R6-23170-L0-00)	CYLINDER, FRTFRK	2	
10	2X7-23151-00-00	.. SPRING, REBOUND	2	
11	39K-23173-00-00	. SPINDLE, TAPER	2	
12	1W1-23114-L0-00	. GASKET	2	
13	(2X7-23340-00-33)	UNDER BRACKET	1	YAMAHA BLACK
14	(3R6-23141-10-00)	SPRING, FRTFRK SOFT	2	U.R. ALTERNATE PARTS6SOFT
	(3R6-23141-20-00)	SPRING, FRTFRK HARD	2	U.R. ALTERNATE PARTS6HARD
	3R6-23141-L0-00	. SPRING, FRONT FORK	2	
15	1W1-23142-L0-00	. SEAT, SPRING UPPER	2	
16	2X3-23191-M0-00	. BOOT, FRONT FORK	2	
17	341-92090-60-00	. BAND, BOOT	1	
18	48Y-23192-00-00	. BAND	1	
19	1W1-23111-L0-00	. BOLT, CAP	2	
20	1W1-23185-L0-00	. COVER, VALVE	2	
21	509-23190-L0-00	. AIR VALVE	2	
22	3R4-23389-00-00	. GUIDE, CABLE	1	
23	509-23163-L0-00	. O-RING	2	
24	509-23158-L0-00	. GASKET	2	
25	122-23129-00-00	. GASKET, DRAIN PLUG	2	

CONTINUED ON NEXT FRAME ►

# FRONT FORK

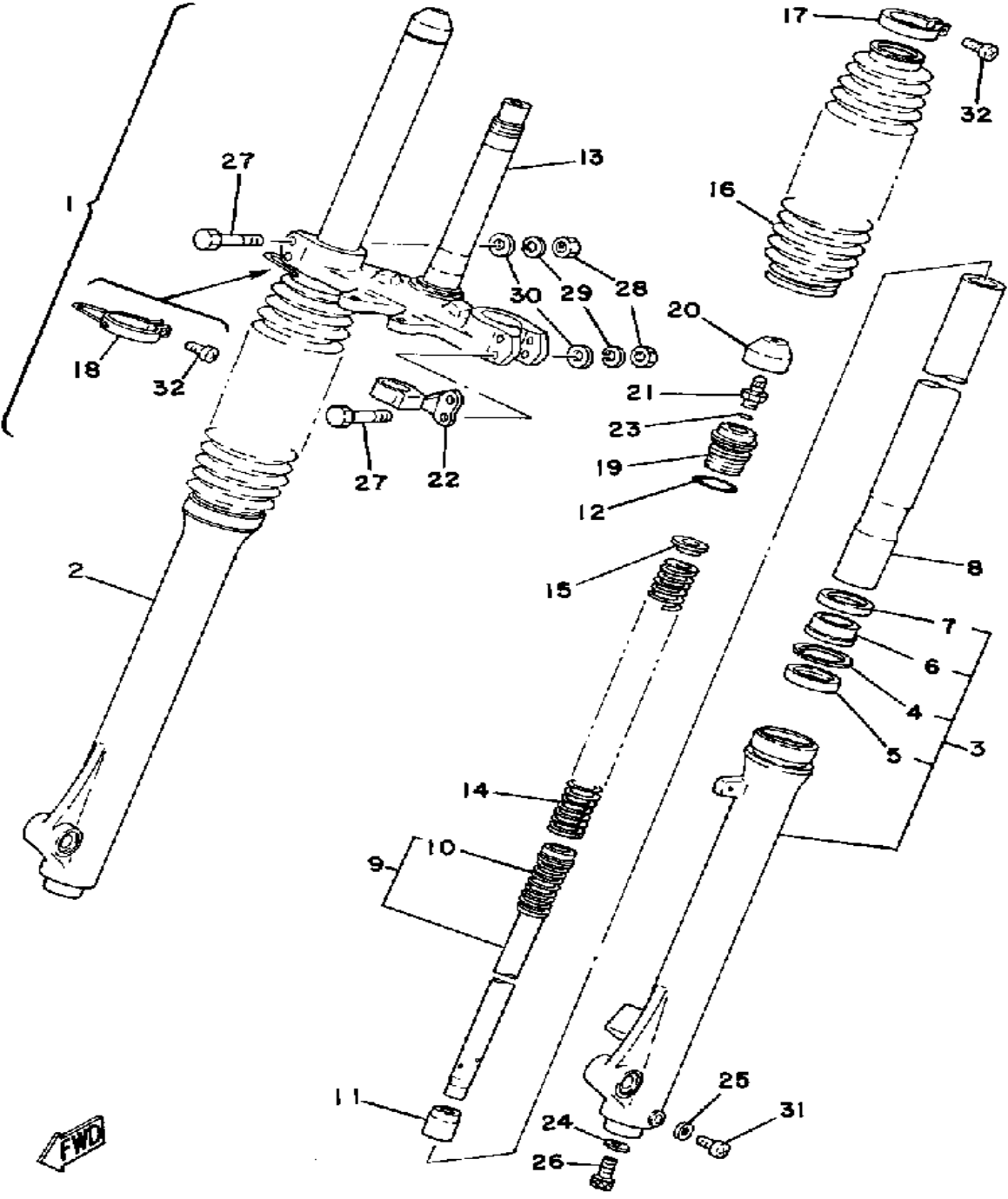

Ref. No.	Part Number	Description	Qty	Remarks
26	278-23181-50-00	. BOLT, HEXAGON SOCKET HEAD .....	2	
27	90101-08340-00	. BOLT .....	4	
28	95333-08600-00	. NUT .....	4	
29	92990-08100-00	. WASHER .....	4	
30	92901-08600-00	. WASHER .....	4	
31	4H7-23119-00-00	. PLUG, DRAIN - (122-23119-01)	2	
32	509-23194-L0-00	. SCREW, BOOT BAND .....	2	

# FUEL TANK

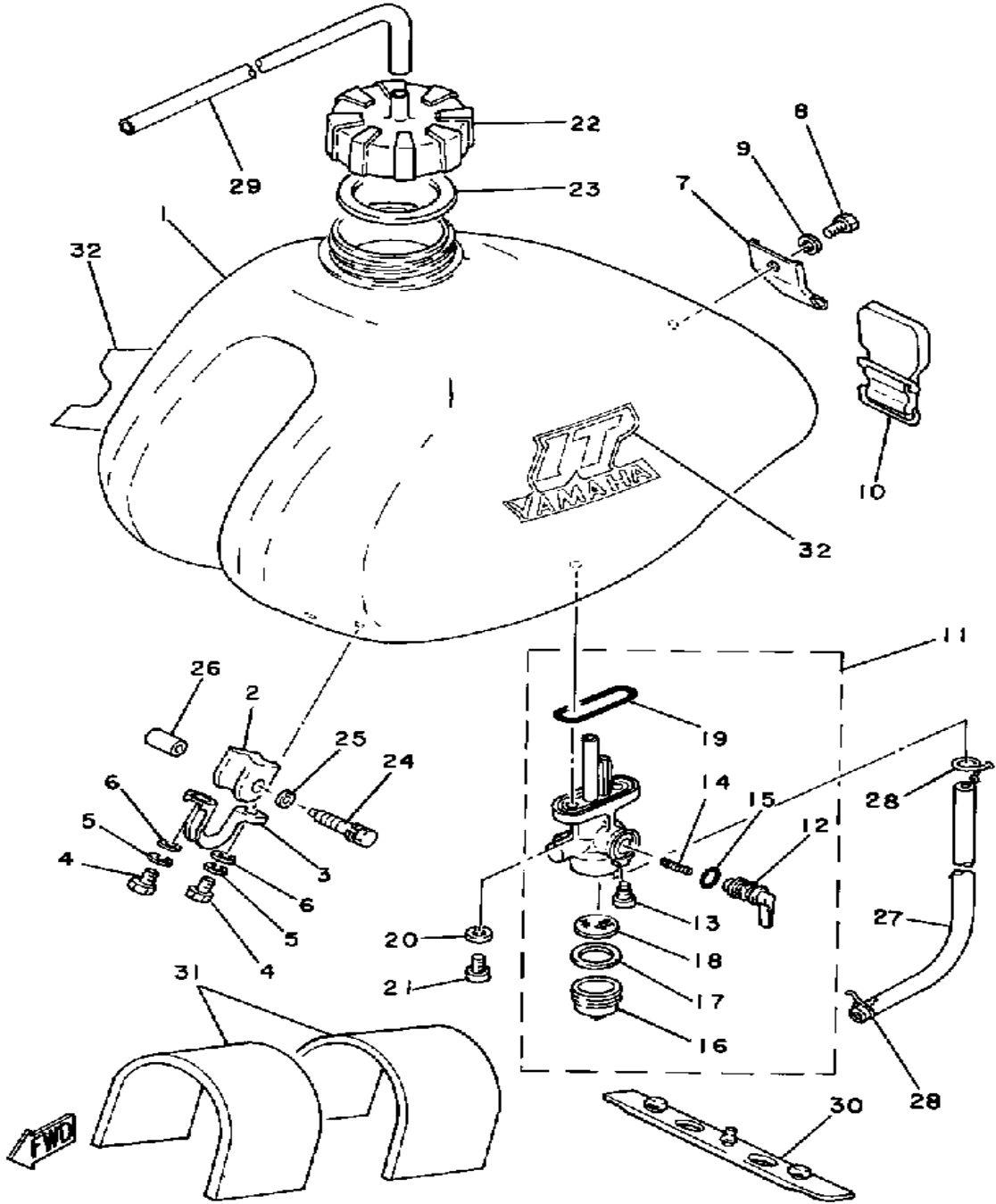

Ref. No.	Part Number	Description	Qty	Remarks
1	3R6-24110-10-00	FUEL TANK	1	CLEAN WHITE
2	1W1-24182-01-00	DAMPER, LOCATING 2	2	
3	1W1-24144-01-00	HOLDER, DAMPER	2	
4	97013-06012-00	BOLT	4	
5	92995-06100-00	WASHER, SPRING	4	
6	92901-06600-00	WASHER	4	
7	(3R6-24192-00-00)	BRACKET, FUEL TNK 2	1	
8	97013-06012-00	BOLT	1	
9	92995-06100-00	WASHER, SPRING	1	
10	1W1-24173-00-00	BAND, TNK FITTING 1	1	
11	3R9-24500-00-00	FUEL COCK ASSEMBLY 1	1	
12	(2W6-24524-00-00)	LEVER, COCK	1	
13	2N3-24535-00-00	. SCREW, LVR FITTING	1	
14	2W6-24529-00-00	. SPRING	1	
15	2N3-24528-00-00	. GASKET	1	
16	(357-24521-10-00)	CUP, FILTER	1	
17	347-24522-10-00	. UNAVAILABLE IN PRICE BOOK	1	
18	2W6-24561-00-00	. NET, FILTER	1	
19	2W6-24512-00-00	. O-RING	1	
20	90202-05187-00	WASHER, PLATE	2	
21	90149-06011-00	SCREW	2	
22	1K7-24611-01-00	BODY, CAP	1	
23	1K7-24612-02-00	GASKET, CAP	1	
24	90119-06022-00	BOLT, WITH WASHER	2	
25	90201-06407-00	WASHER, PLATE (90201-06747-00)	2	
26	90387-07393-00	COLLAR (308-84557-00)	2	
27	90445-11150-00	HOSE (363-24311-00)	1	

Basic Color(s)	White
Fuel Type / Fuel Tank Capacity / Reserve Capacity	Premium / 11 Lit. (2.9 Gal.) / 0

CONTINUED ON NEXT FRAME ►

# FUEL TANK

Ref. No.	Part Number	Description	Qty	Remarks
28	90467-10008-00	CLIP	2	
29	90445-09361-00	HOSE	1	
30	3R4-24181-00-00	DAMPER, LOCATING 1	1	
31	1W1-24183-00-00	DAMPER, LOCATING 3	2	
32	(3R9-24161-19-00)	EMBLEM 1	2	

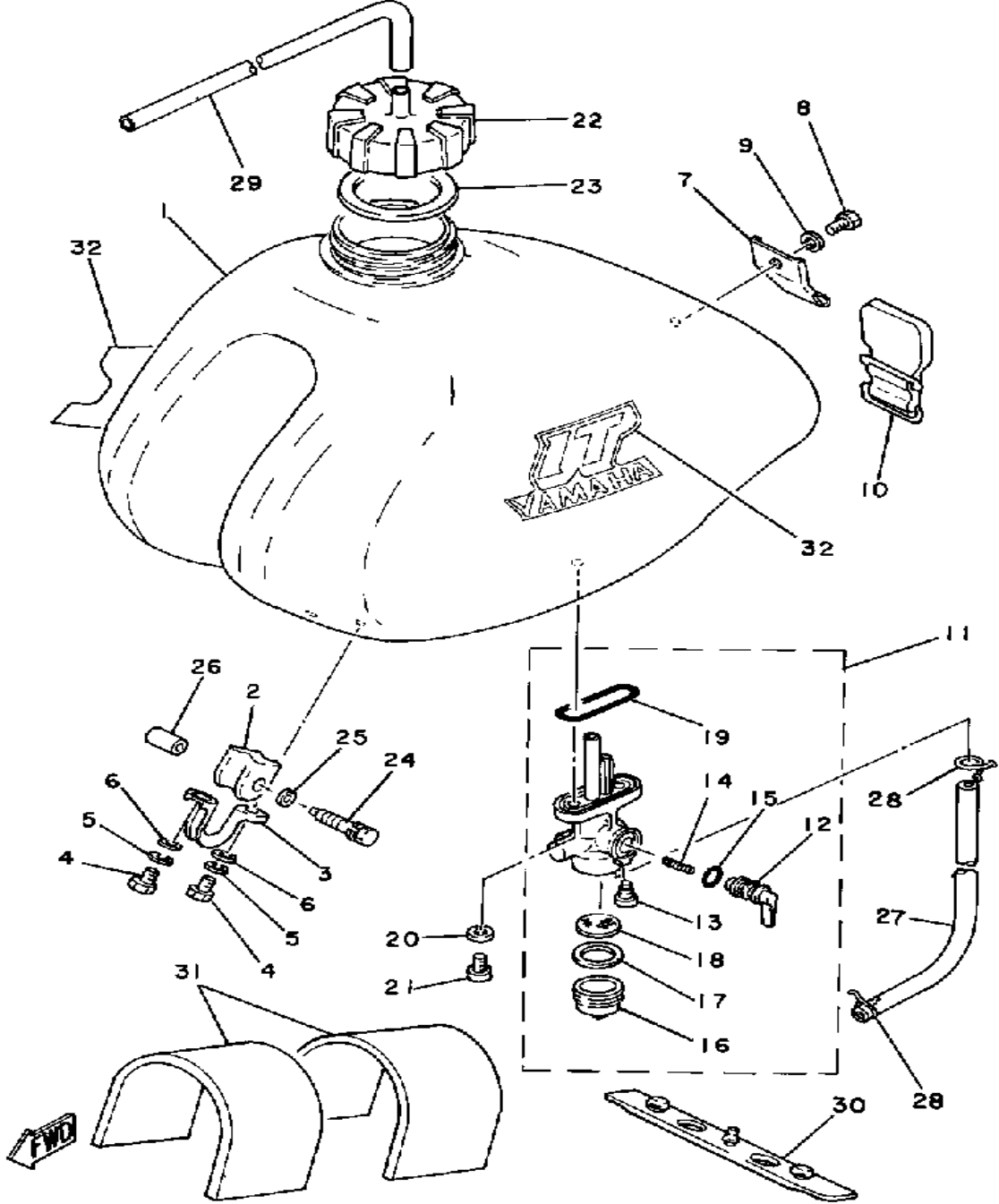

Basic Color(s)	White
Fuel Type / Fuel Tank Capacity / Reserve Capacity	Premium / 11 Lit. (2.9 Gal.) / 0

# SEAT

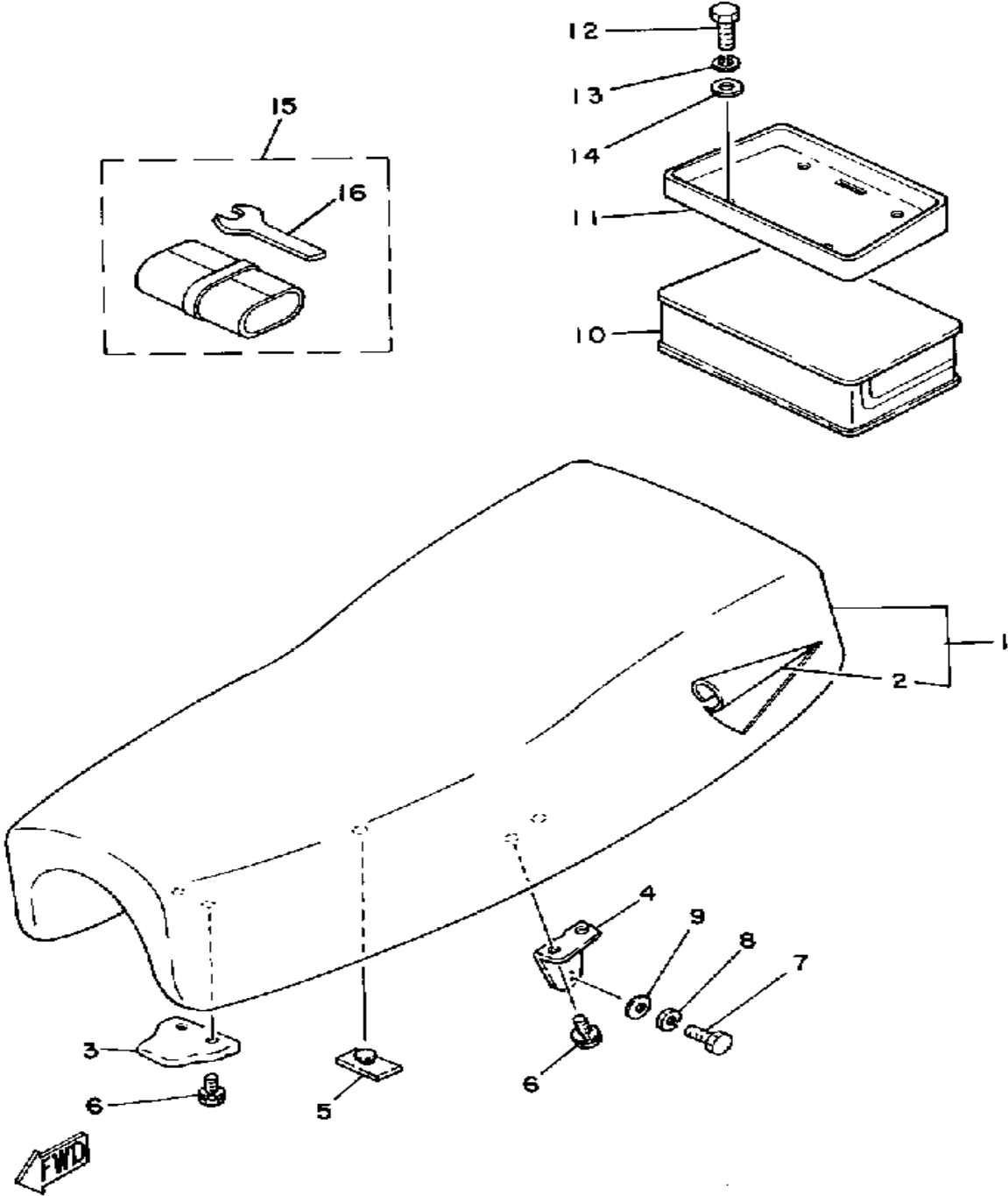

Ref. No.	Part Number	Description	Qty	Remarks
1	(3R6-W2473-10-00)	SEMI-DBL-SEAT ASSEMBLY ..	1	
2	3R6-24771-10-00	. COVER, SM-DBL SEAT .....	1	
3	1M1-24748-00-00	BRACKET, SEAT .....	1	
4	509-24738-01-00	BRACKET, SEAT .....	2	
5	509-24724-00-00	DAMPER, SEAT .....	6	
6	90101-06304-00	BOLT .....	6	
7	97301-06014-00	BOLT, HEXAGON .....	2	
8	92995-06100-00	WASHER, SPRING .....	2	
9	92901-06600-00	WASHER .....	2	
10	4V5-24850-00-00	CARRIER BOX ASSEMBLY ...	1	
11	4V5-24833-00-00	BRACKET, CARRIER 2 .....	1	
12	97001-06018-00	BOLT .....	3	
13	92995-06100-00	WASHER, SPRING .....	3	
14	90201-06067-00	WASHER, PLATE .....	3	
15	1W2-W2810-00-00	TOOL KIT .....	1	
16	10V-28135-00-00	. SPANNER, SPECIAL .....	1	

# FRONT WHEEL

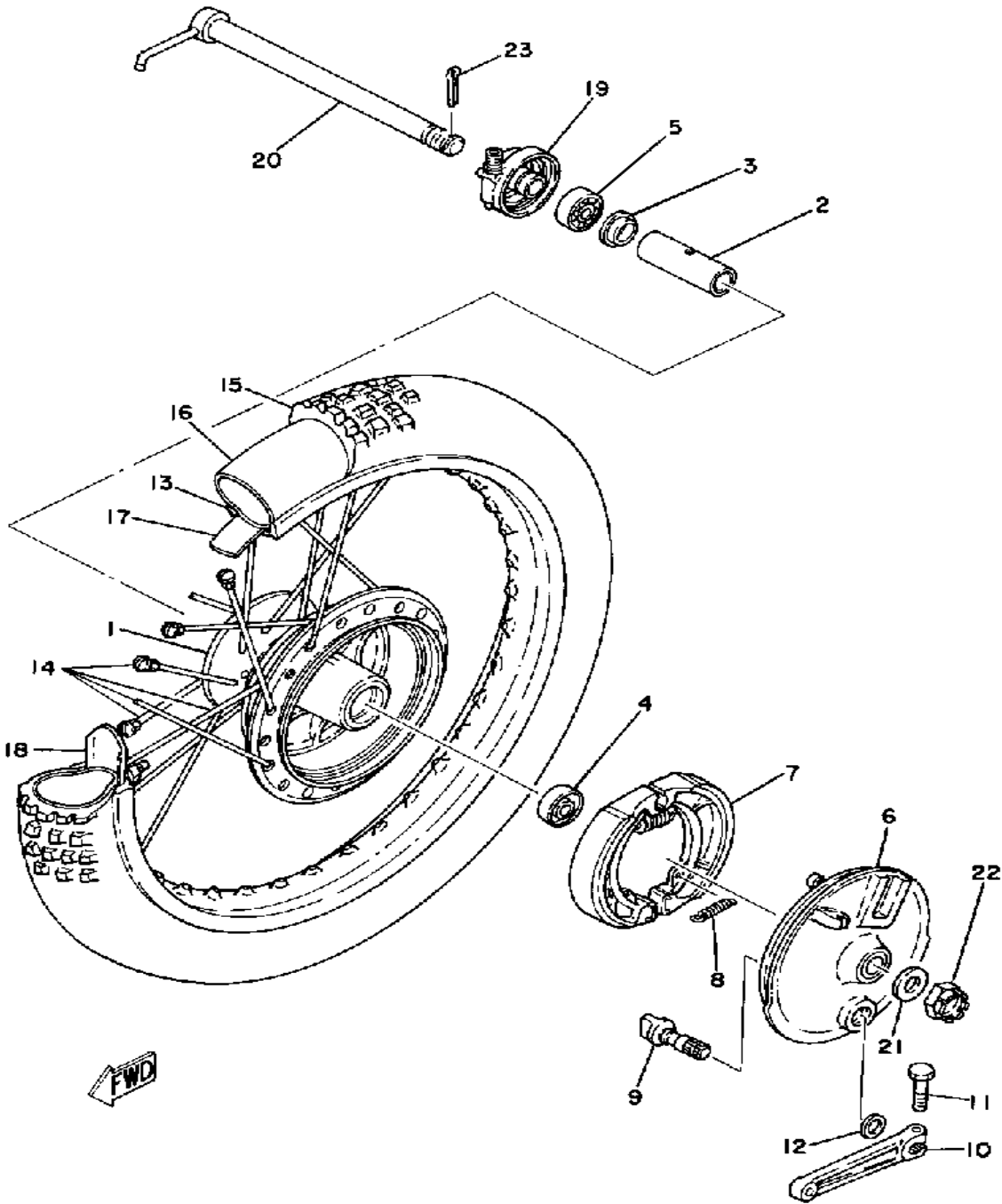

Ref. No.	Part Number	Description	Qty	Remarks
1	1K7-25111-10-98	HUB, FRONT	1	LOW GLOSS BLK
2	90560-15116-00	SPACER	1	
3	146-25116-00-00	FLANGE, SPACER 2	1	
4	93306-20226-00	BEARING	1	
5	93306-20209-00	BEARING (B6202)	1	
6	1W1-25016-11-98	BRAKE SHOE PLT ASSEMBLY (1W1-25121-02-98)	1	LOW GLOSS BLK
7	322-W2535-00-00	BRAKESHOE SET-2PCS	2	
8	90506-17328-00	SPRING, TENSION	2	
9	23X-25151-00-00	CAMSHAFT	1	
10	322-25155-00-00	LEVER, CAMSHAFT 1	1	
11	90101-06291-00	BOLT	1	
12	137-25159-00-00	SEAL, CAMSHAFT	1	
13	94416-21234-00	RIM 1.60X 1	1	
14	2W6-25104-02-00	SPOKE SET, FRONT	1	
15	(94130-21584-00)	IRC 300X21 VE- 1	1	
16	94230-21126-00	TUBE (3.00-21)	1	
17	(94330-21088-00)	BAND, RIM	1	
18	1T1-25194-00-00	SPACER, BEAD	1	
19	1W2-25190-00-00	GEAR UNIT ASSEMBLY	1	
20	1W2-25181-02-00	AXLE, WHEEL	1	
21	90201-15785-00	WASHER, PLATE	2	
22	90171-14020-00	NUT, CASTLE	1	
23	91401-30030-00	PIN, COTTER	1	

# REAR WHEEL

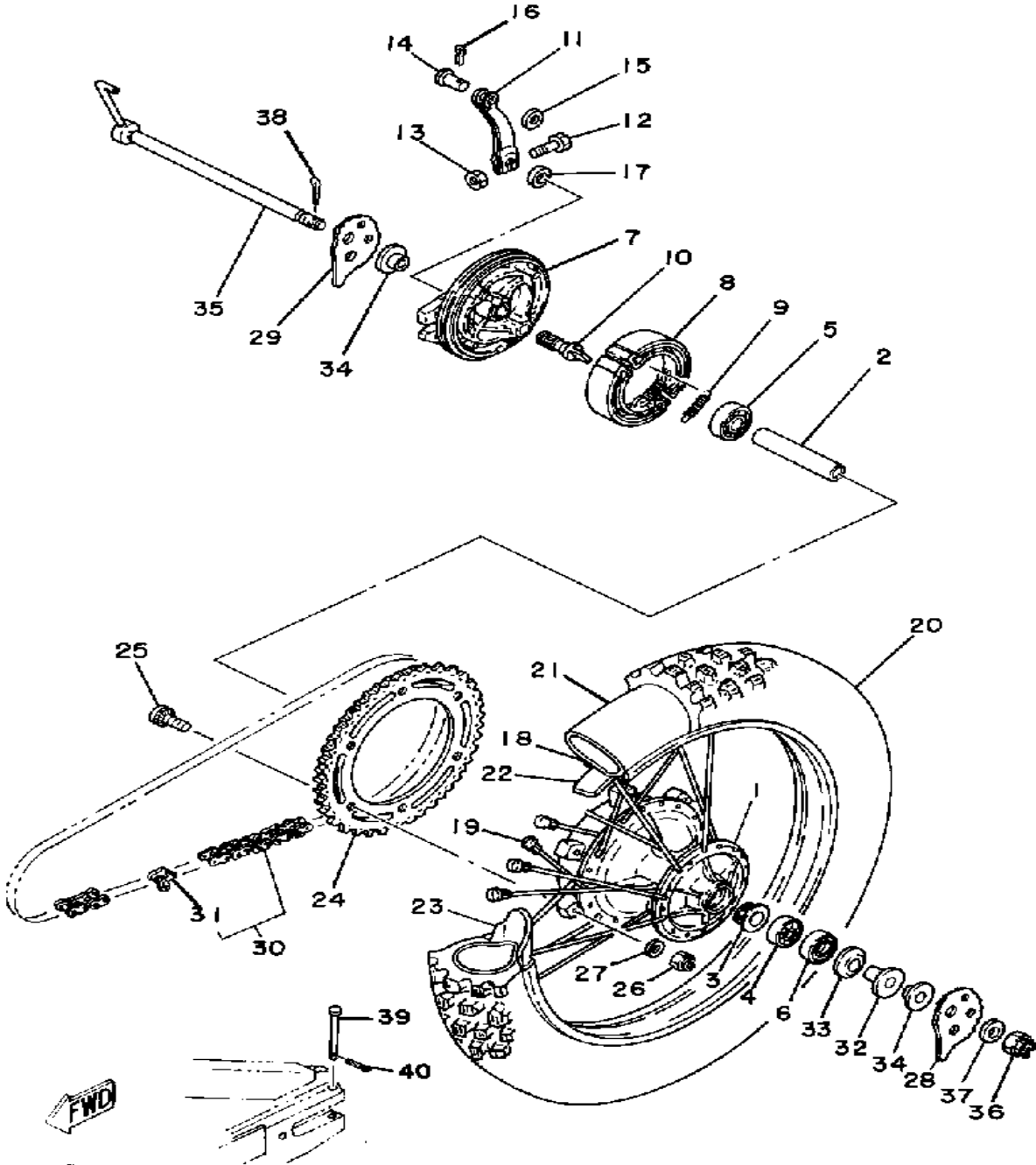

Ref. No.	Part Number	Description	Qty	Remarks
1	3R3-25311-02-98	HUB, REAR	1	LOW GLOSS BLK
2	3R3-25317-00-00	SPACER, BEARING	1	
3	146-25116-00-00	FLANGE, SPACER 2	1	
4	93306-20209-00	BEARING (B6202)	1	
5	93306-30202-00	BEARING	1	
6	93106-22017-00	OIL SEAL, DD-TYPE	1	
7	99999-02025-00	PLATE, BRAKE SHOE	1	LOW GLOSS BLK
8	437-W2536-00-00	BRAKESHOE SET-2PCS	2	
9	90506-17328-00	SPRING, TENSION	2	
10	401-25351-00-00	CAMSHAFT	1	
11	3R6-25355-01-00	LEVER, CAMSHAFT	1	
12	90101-06278-00	BOLT	1	
13	95380-06600-00	NUT	1	
14	3R6-27237-00-00	PIN, CLEVIS	1	
15	90201-12631-00	WASHER, PLATE	1	
16	91401-25030-00	PIN, COTTER	1	
17	148-25359-00-00	SEAL, CAMSHAFT	1	
18	94418-18245-00	RIM 1.85X 8	1	
19	4V2-25304-00-00	SPOKE SET, REAR	1	
20	(94141-18655-00)	410-18 MARK 2 (TT)	1	
21	94235-18085-00	TUBE	1	
22	94325-18043-00	BAND, RIM	1	
23	2X3-25394-00-00	SPACER, BEAD	2	
24	26A-25442-50-00	SPROCKET, DRIVN 42T	1	
	26A-25444-50-00	SPROCKET, DRIVEN (44T)	1	U.R. STD6YAMAHA BLACK
	26A-25446-50-33	SPROCKET, DRIVEN (46T) (26A-25446-50-00)	1	U.R. YAMAHA BLACK
25	90110-08038-00	BOLT, HEX SKT HEAD	6	

CONTINUED ON NEXT FRAME ►



# REAR WHEEL

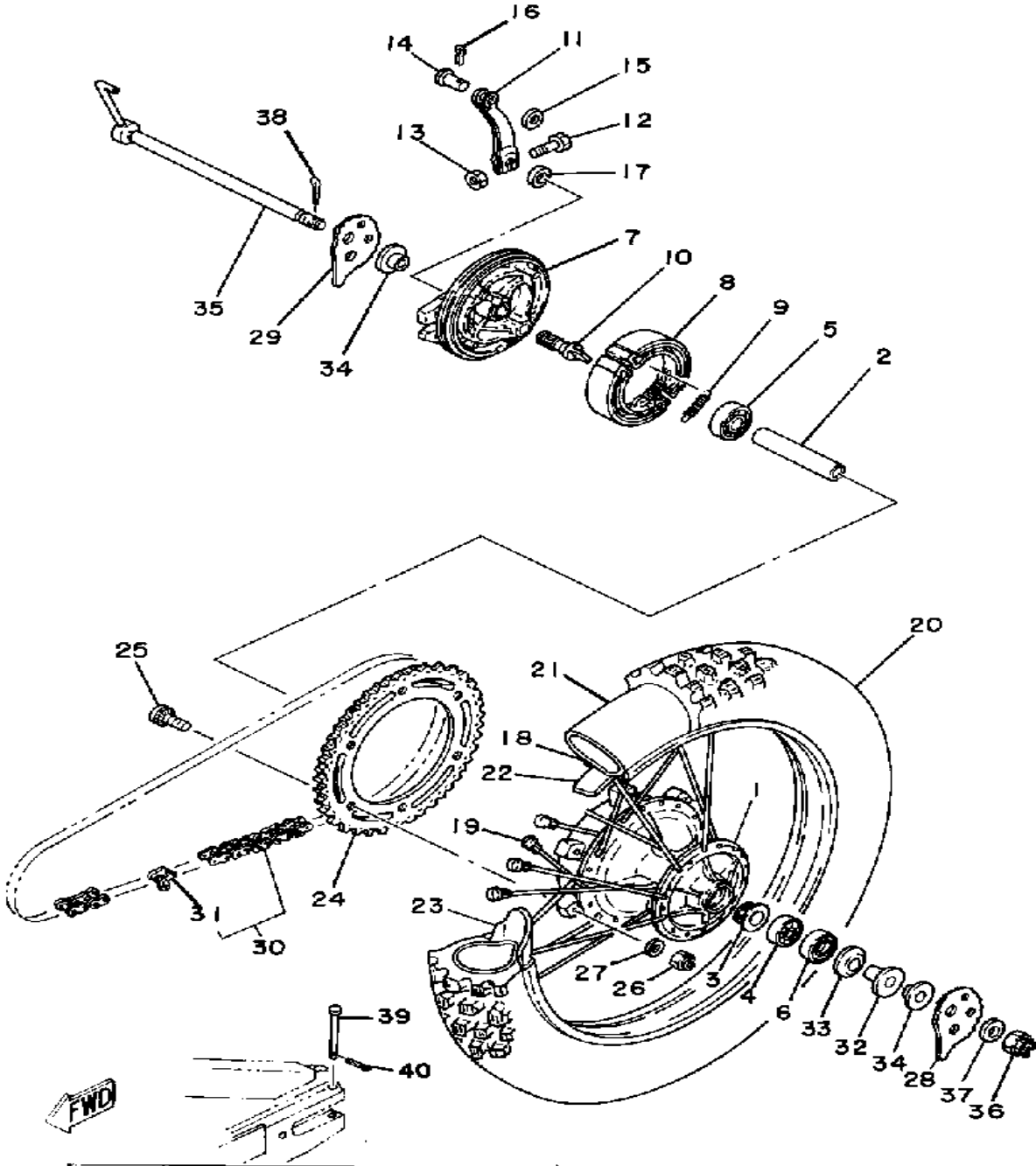

Ref. No.	Part Number	Description	Qty	Remarks
26	90185-08089-00	NUT, SELF-LOCKING	6	
27	92990-08200-00	WASHER, PLAIN	6	
28	1W2-25388-01-00	PULLER, CHAIN 1	1	
29	1W2-25389-01-00	PULLER, CHAIN 2	1	
30	94585-20100-00	CHAIN 520DS-100L	1	
31	94685-20001-00	. JOINT CHAIN	1	
32	90387-152A3-00	COLLAR	1	
33	3R3-25367-00-00	COVER, HUB DUST	1	
34	90381-15034-00	BUSH, SOLID	2	
35	3R6-25381-00-00	AXLE, WHEEL	1	
36	90171-14020-00	NUT, CASTLE	1	
37	90201-15238-00	WASHER, PLATE	1	
38	91401-30030-00	PIN, COTTER	1	
39	91702-06055-00	PIN, clevis	2	
40	91490-20020-00	PIN, COTTER	2	

Minimum Brake Lining Thickness	Front: 2.0mm	Rear: 2.0mm
Tire Size (Nominal Pressure)	F: 3.00-21 (Pressure Opt.)	R: 4.10-18 (Pressure Opt.)
Rear Axle Nut	14 x 1.5: 8.5 m.kg	

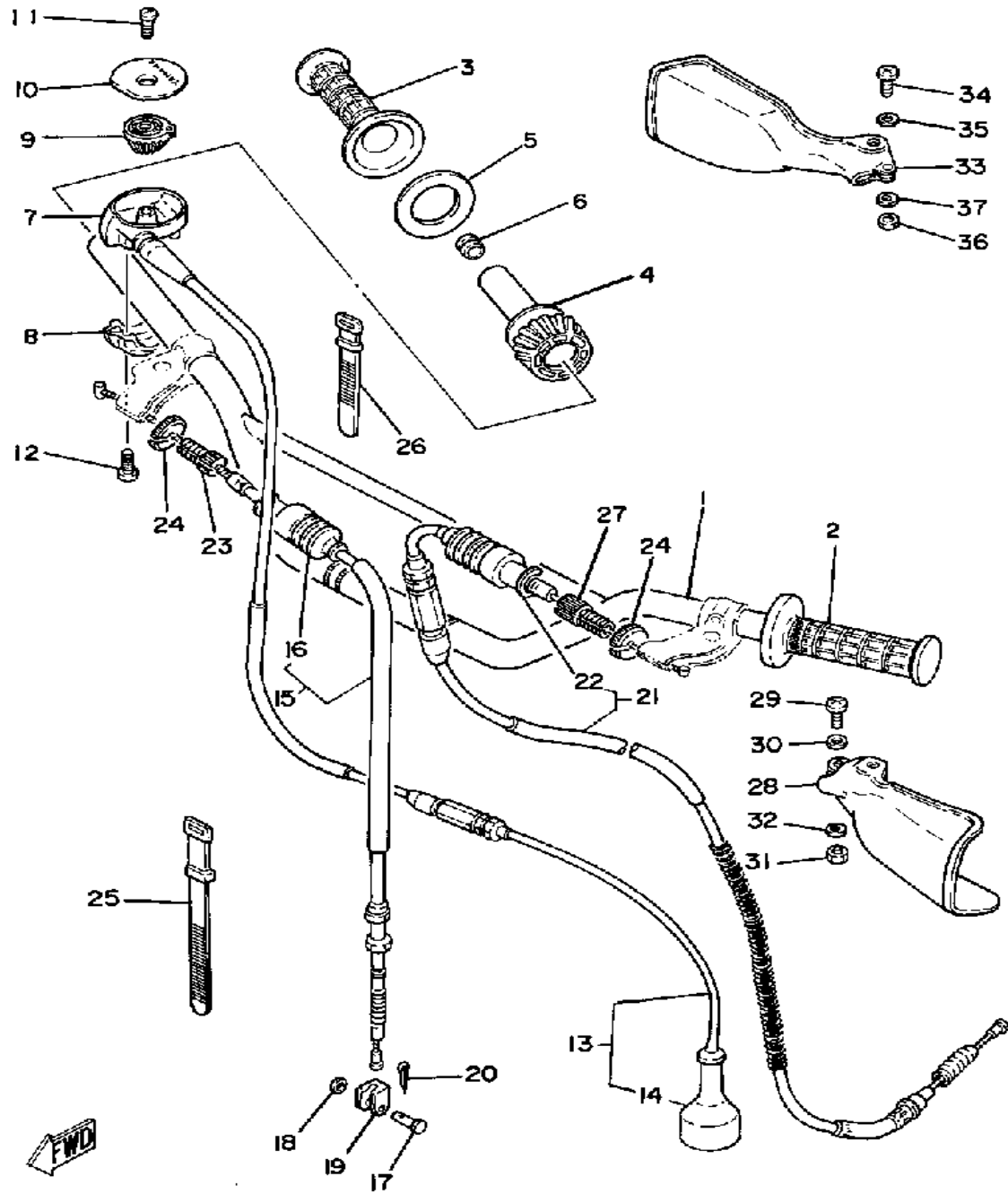

# HANDLEBAR-CABLE

Ref. No.	Part Number	Description	Qty	Remarks
1	3R6-26111-00-00	HANDLEBAR .....	1	
2	4V4-26241-01-00	GRIP (L.H.) (4V4-26241-00) ...	1	
3	1LX-26242-01-00	GRIP (RIGHT) .....	1	
4	4V6-26243-00-00	TUBE, THRTL GUIDE .....	1	
5	4V4-26249-00-00	RING, LEAF .....	1	
6	90338-12192-00	PLUG .....	1	
7	4V4-26281-00-00	CAP, GRIP UPPER .....	1	
8	4V4-26282-00-00	CAP, GRIP LOWER .....	1	
9	4V6-2628E-00-00	GEAR, BEVEL .....	1	
10	4V4-2628F-09-00	CAP, GEAR (4V4-2628F-00) ...	1	
11	98906-05010-00	SCREW, BIND .....	1	
12	98580-05016-00	SCREW, PAN HEAD .....	2	
13	3R6-26311-10-00	CABLE, THROTTLE 1 .....	1	
14	500-26329-01-00	. CAP, RUBBER .....	1	
15	3R6-26341-01-00	CABLE, BRAKE .....	1	
16	1E6-26342-00-00	. BOOT, CABLE .....	1	
17	90240-08013-00	PIN, CLEVIS .....	1	
18	90201-08083-00	WASHER, PLATE .....	1	
19	156-26347-00-00	JOINT, CABLE .....	1	
20	91490-20020-00	PIN, COTTER .....	1	
21	3R3-26335-02-00	CABLE, CLUTCH .....	1	
22	1E6-26342-00-00	. BOOT, CABLE .....	1	
23	90123-08046-00	BOLT .....	1	
24	90179-08148-00	NUT .....	2	
25	437-83936-11-00	BAND, SWITCH CORD .....	1	
26	437-83936-01-00	BAND, SWITCH CORD .....	1	
27	90123-08046-00	BOLT .....	1	
28	3Y0-26141-00-00	GUARD, BRUSH 1 .....	1	WHITE
29	98503-06014-00	SCREW, PAN HEAD (92502-06016) .....	1	

CONTINUED ON NEXT FRAME ➤

# HANDLEBAR-CABLE

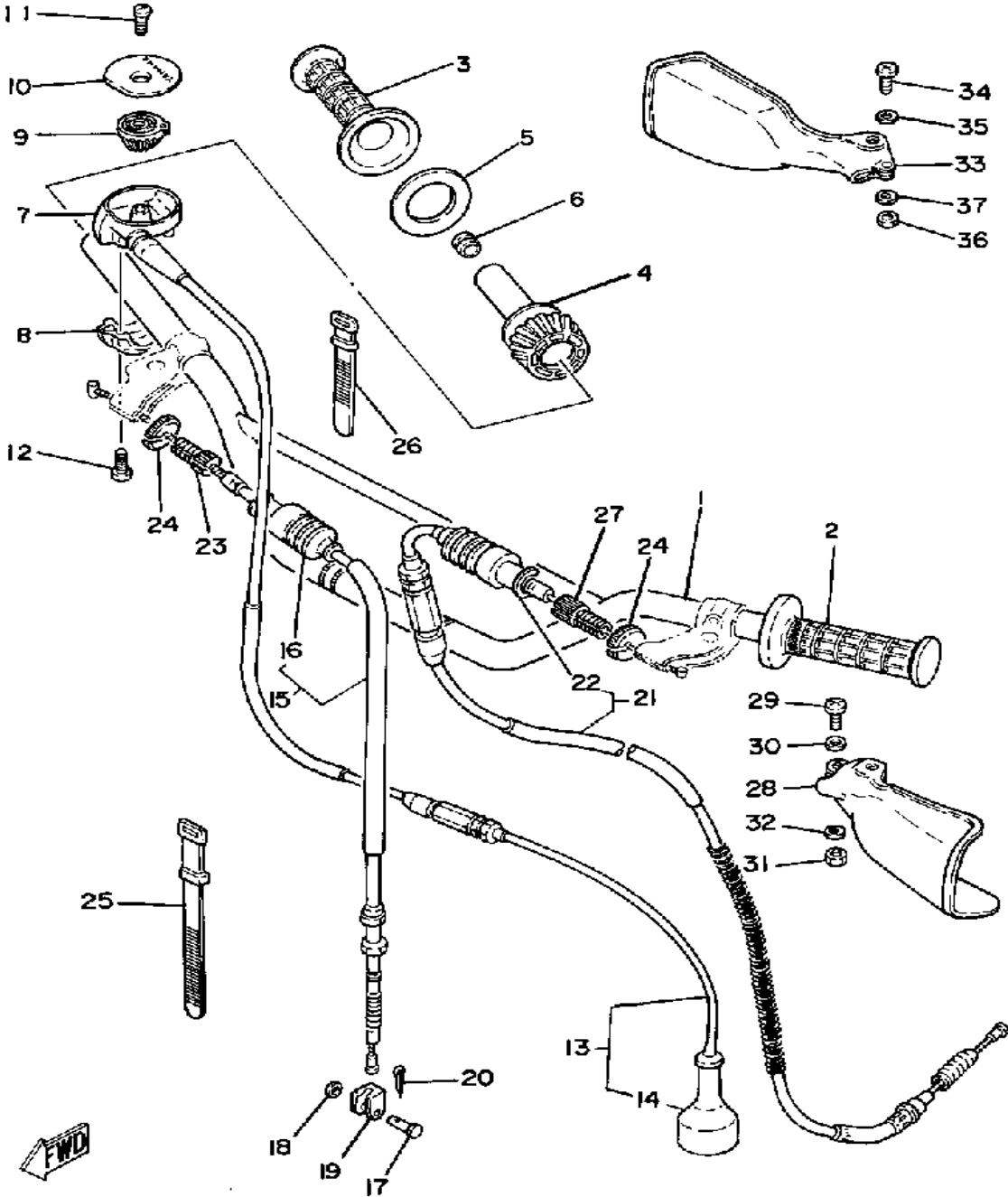

Ref. No.	Part Number	Description	Qty	Remarks
30	92901-06600-00	WASHER .....	1	
31	95380-06700-00	NUT .....	1	
32	92990-06200-00	WASHER .....	1	
33	3Y0-26142-00-00	GUARD, BRUSH 2 .....	1	WHITE
34	98503-06014-00	SCREW, PAN HEAD (92502-06016) .....	1	
35	92901-06600-00	WASHER .....	1	
36	95380-06700-00	NUT .....	1	
37	92990-06200-00	WASHER .....	1	

# STAND-FOOTREST

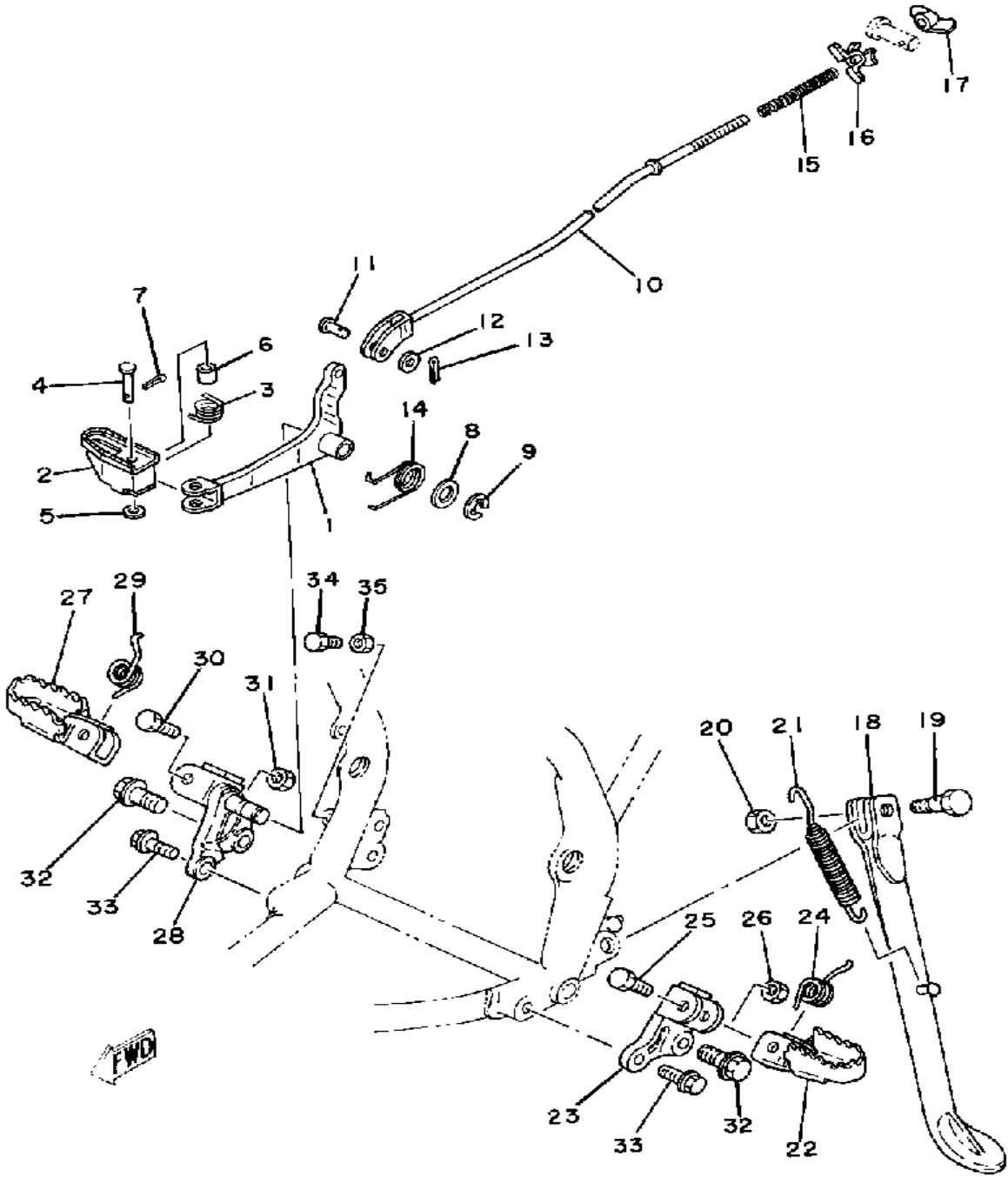

Ref. No.	Part Number	Description	Qty	Remarks
1	(3R6-27211-01-90)	PEDAL, BRAKE .....	1	UNI CHROME6(BLACK)
2	3R6-27242-00-00	PEDAL, BRAKE .....	1	
3	90508-20451-00	SPRING, TORSION .....	1	
4	91701-08032-00	PIN, CLEVIS .....	1	
5	92901-08600-00	WASHER .....	1	
6	90387-08762-00	COLLAR .....	1	
7	91401-25020-00	PIN, COTTER .....	1	
8	92990-12200-00	WASHER, PLAIN .....	1	
9	93430-09038-00	CIRCLIP .....	1	
10	3R6-27231-00-00	ROD, BRAKE .....	1	
11	90240-06103-00	PIN, CLEVIS .....	1	
12	92990-06200-00	WASHER .....	1	
13	91490-20020-00	PIN, COTTER .....	1	
14	90508-32455-00	SPRING, TORSION .....	1	
15	90501-10245-00	SPRING, COMPRESSION .....	1	
16	1W2-27239-00-00	SEAT, SPRING .....	1	
17	90179-06411-00	NUT .....	1	
18	1W1-27311-10-00	STAND, SIDE .....	1	YAMAHA BLACK
19	90109-103A1-00	BOLT .....	1	
20	95303-10700-00	NUT .....	1	
21	90507-29008-00	SPRING, TENSION .....	1	
22	5X3-27411-00-00	FOOTREST 1 (250H) .....	1	
23	4V2-27412-01-00	BRACKET, FOOTREST 1 (4V2-27412-00) .....	1	
24	90508-20023-00	SPRING, TORSION .....	1	
25	90101-08428-00	BOLT .....	1	
26	95611-08100-00	NUT, U .....	1	
27	4V4-27421-00-00	FOOTREST 2 (250H) .....	1	

CONTINUED ON NEXT FRAME ►

# STAND-FOOTREST

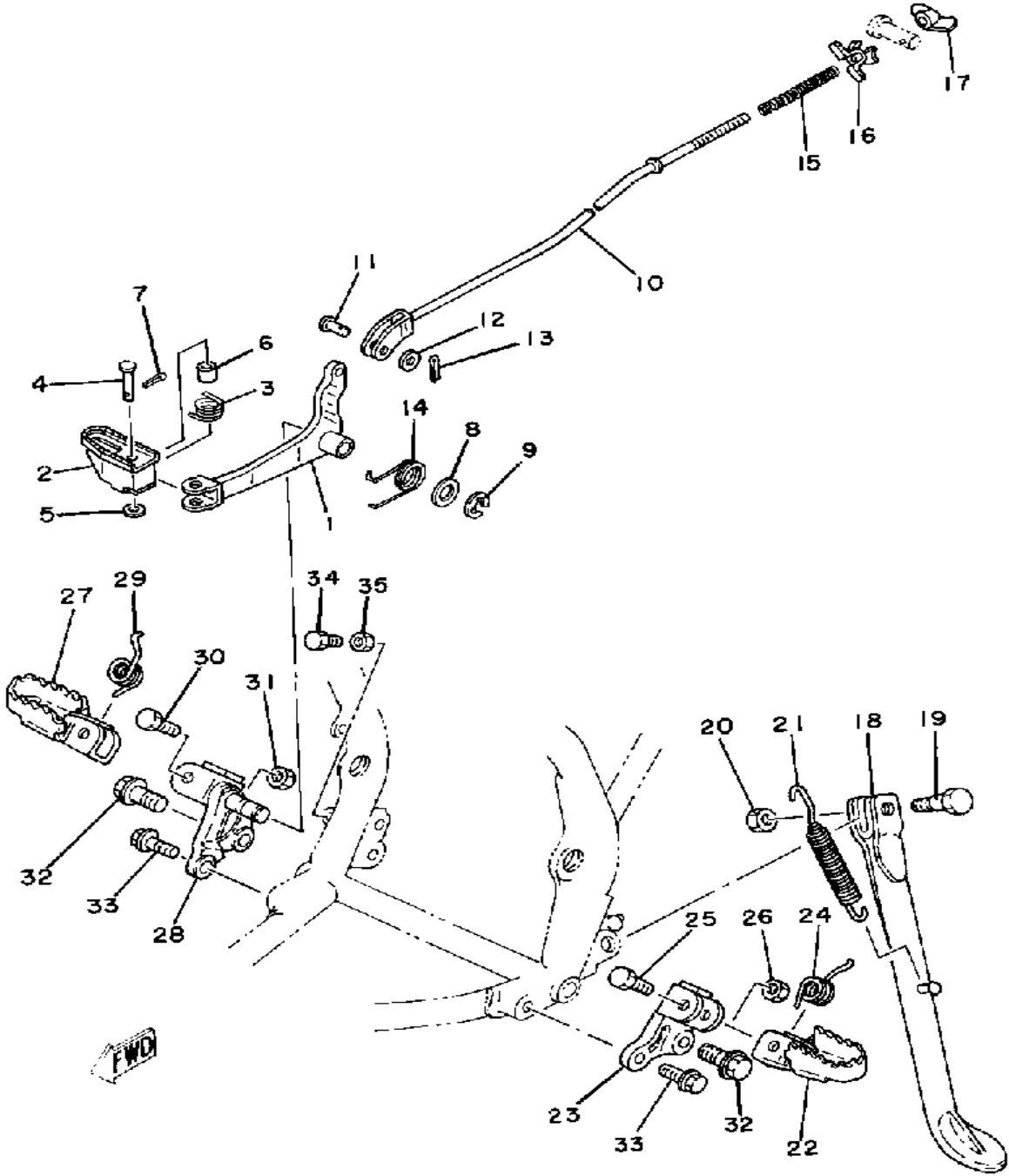

Ref. No.	Part Number	Description	Qty	Remarks
28	3R6-27422-10-00	BRACKET, FOOTREST 2	1	
29	90508-20023-00	SPRING, TORSION	1	
30	90101-08428-00	BOLT	1	
31	95611-08100-00	NUT, U	1	
32	90105-12096-00	BOLT, WASHER BASED	2	
33	95811-10020-00	BOLT, FLANGE (95822-10020-00)	2	
34	97023-06020-00	BOLT (3XF)	1	
35	95380-06700-00	NUT	1	

# METER

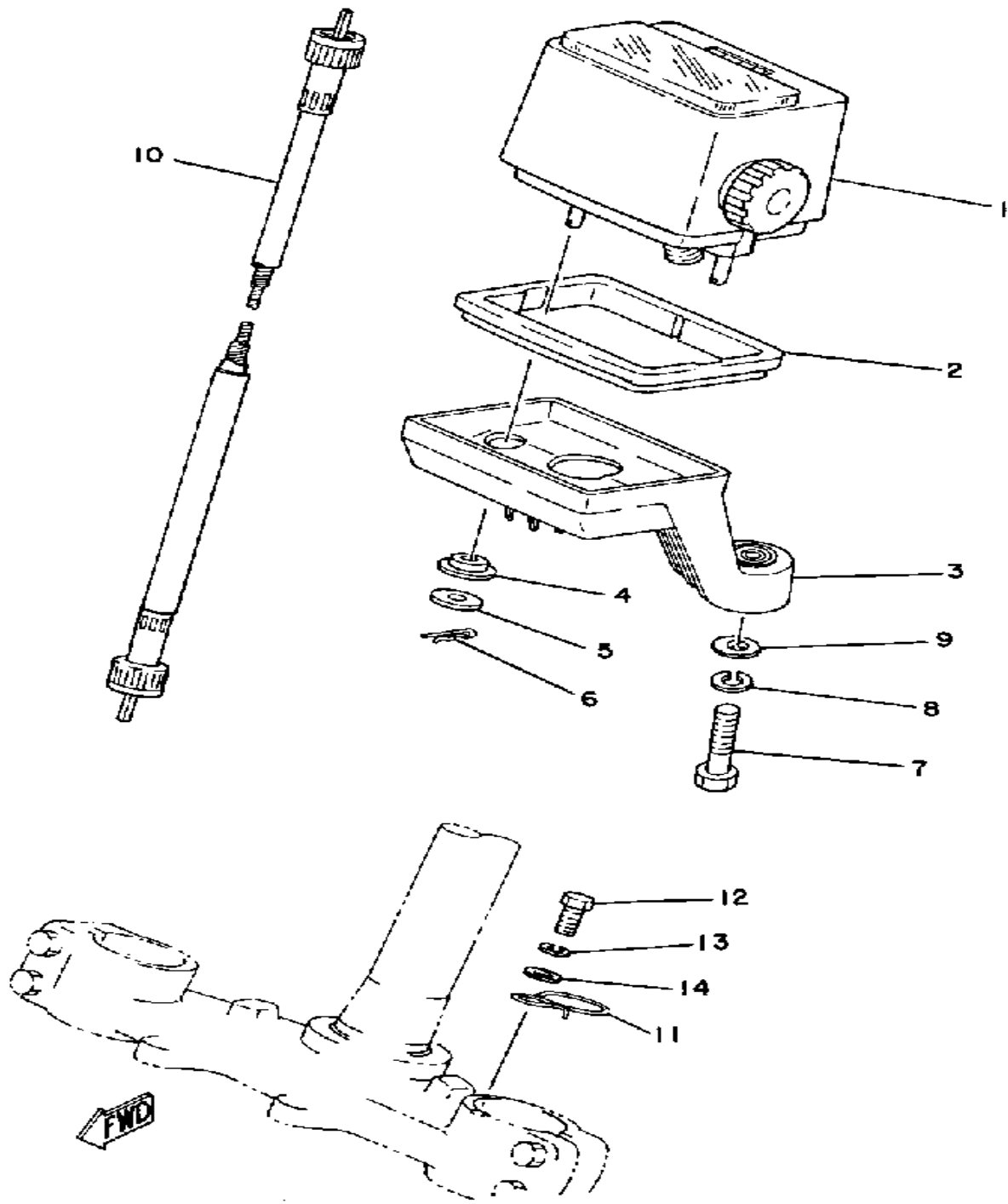

Ref. No.	Part Number	Description	Qty	Remarks
1	3R8-83570-60-00	SPEEDOMETER ASSEMBLY ..	1	U.R.
2	3R8-83513-00-00	DAMPER .....	1	
3	3R8-83519-00-00	BRACKET, METER .....	1	
4	1M1-83526-00-00	DAMPER 2 .....	2	
5	90201-052E2-00	WASHER, PLATE .....	2	
6	90468-10050-00	CLIP .....	2	
7	97021-06030-00	BOLT .....	2	
8	92995-06100-00	WASHER, SPRING .....	2	
9	92901-06600-00	WASHER .....	2	
10	34X-83550-01-00	SPEEDOMETER CABLE ASSEMBLY .....	1	
11	(2A6-83595-00-00)	CLAMP .....	1	
12	97013-06012-00	BOLT .....	1	
13	92995-06100-00	WASHER, SPRING .....	1	
14	92901-06600-00	WASHER .....	1	

# HEADLIGHT

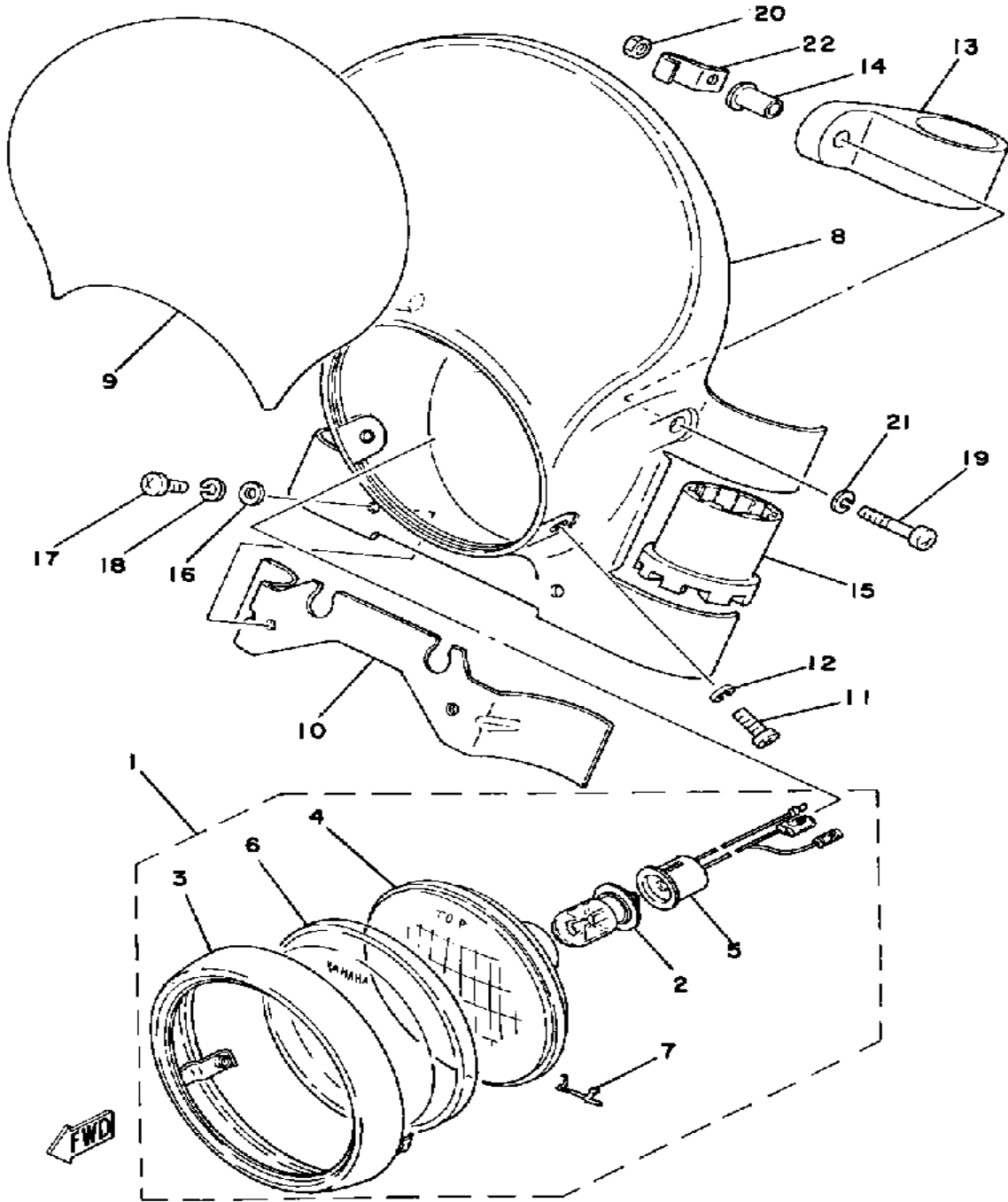

Headlight / Taillight / Signal Rating      6V25-25W / 6V5W / 2

Ref. No.	Part Number	Description	Qty	Remarks
1	(3R8-84110-01-00)	UNAVAILABLE IN PRICE BOOK	1	N/A
2	527-84114-09-XX	. BULB, HL 6V25/25W	1	
3	3R8-84115-60-00	. RIM, HEADLIGHT	1	
4	3R8-84120-60-00	. LENS ASSEMBLY	1	
5	3R8-84140-61-00	. SOCKET CORD ASSEMBLY 0 1	1	
6	3R8-84144-60-00	. COVER, HEADLIGHT	1	
7	1W2-84324-60-00	. SPRING, REFLECTOR	4	
8	3Y0-84130-00-00	BODY ASSEMBLY, HEADLIGHT	1	CLEAN WHITE
9	3R8-84141-01-00	EMBLEM, HEADLIGHT	1	
10	3R8-84181-00-00	BRACKET, LOWER 1	1	
11	98580-05016-00	SCREW, PAN HEAD	2	
12	92990-05100-00	WASHER, SPRING	2	
13	(3R8-84163-00-00)	DAMPER	2	
14	3R8-84133-00-00	COLLAR, SCREW	2	
15	3R8-84164-00-00	DAMPER	2	
16	90201-06571-00	WASHER, PLATE	2	
17	98580-06012-00	SCREW, PAN HEAD	2	
18	92995-06100-00	WASHER, SPRING	2	
19	98580-06030-00	SCREW PAN HEAD	2	
20	90185-06062-00	NUT, SELF-LOCKING	2	
21	90201-06407-00	WASHER, PLATE (90201-06747-00)	2	
22	90462-05005-00	CLAMP	1	

# TAILLIGHT

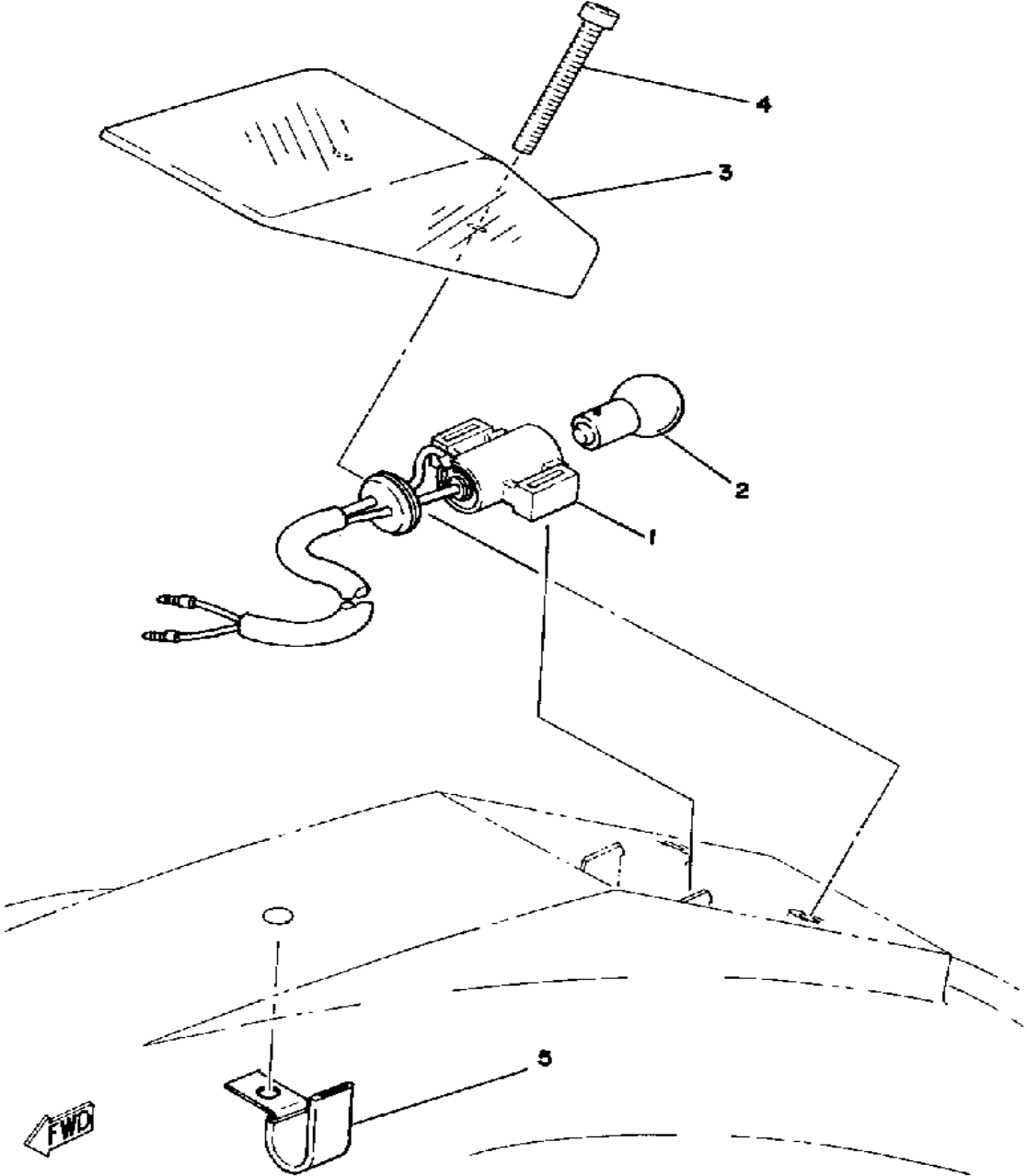

Ref. No.	Part Number	Description	Qty	Remarks
1	54G-84530-00-00	SOCKET ASSEMBLY .....	1	
2	3R9-84514-00-00	BULB .....	1	
3	3R9-84521-00-00	LENS, TAILLIGHT .....	1	
4	98501-04035-00	SCREW, PAN HEAD .....	2	
5	90462-05005-00	CLAMP .....	1	

Headlight / Taillight / Signal Rating	6V25-25W / 6V5W / 0
---------------------------------------	---------------------



# ELECTRICAL 1

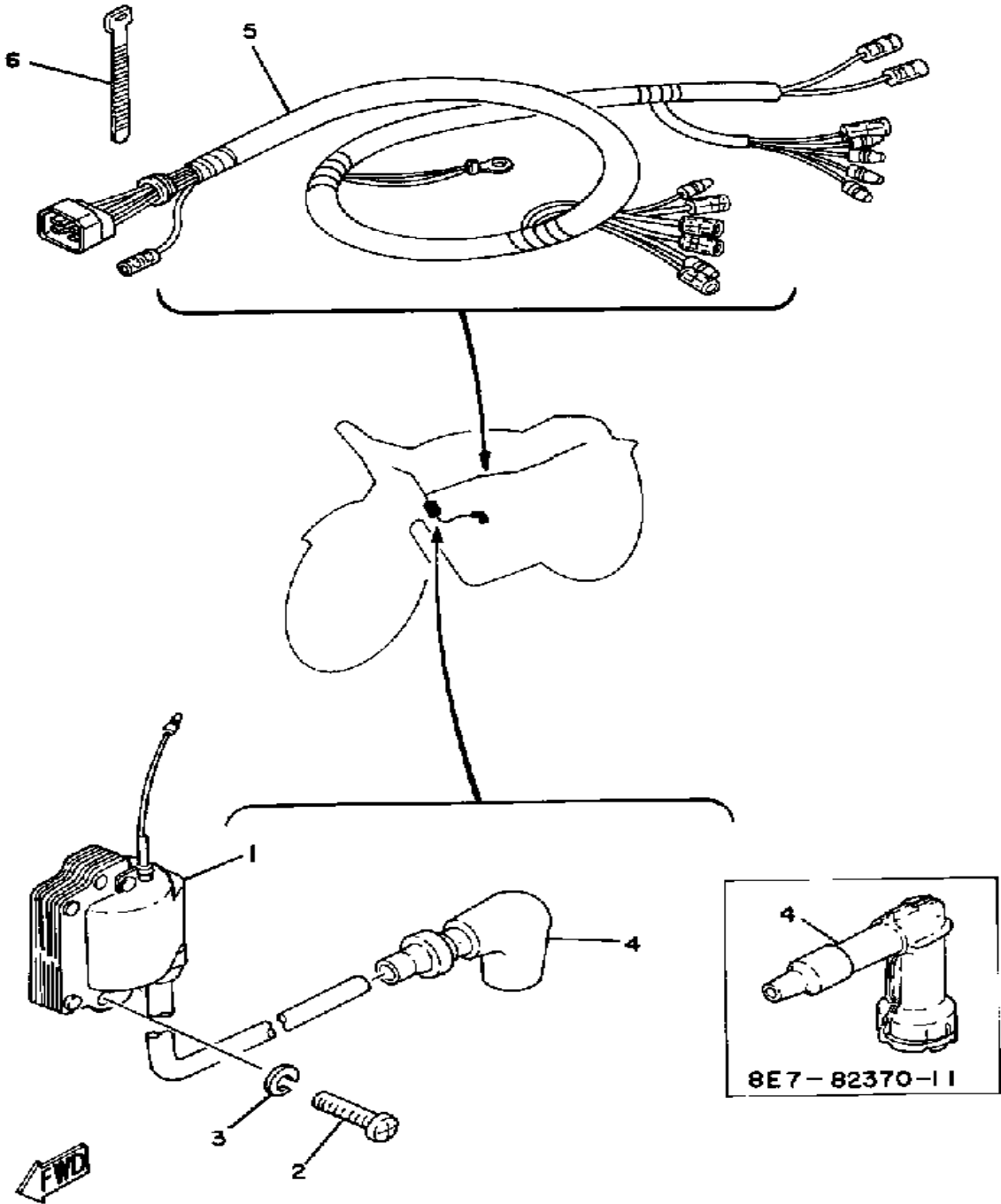

Ref. No.	Part Number	Description	Qty	Remarks
1	5G4-82310-40-00	IGNITION COIL ASSEMBLY (J17-82310-21)	1	
2	98511-06025-00	SCREW PAN HEAD (92501-06025)	2	
3	92995-06100-00	WASHER, SPRING	2	
4	81E-82370-20-00	PLUG CAP ASSEMBLY	1	U.R.
	8E7-82370-11-00	PLUG CAP ASSEMBLY	1	U.R.
5	(3R6-82590-00-00)	WIRE HARNESS ASSEMBLY	1	
6	437-83936-01-00	BAND, SWITCH CORD	4	

# HANDLE SWITCH-LEVER

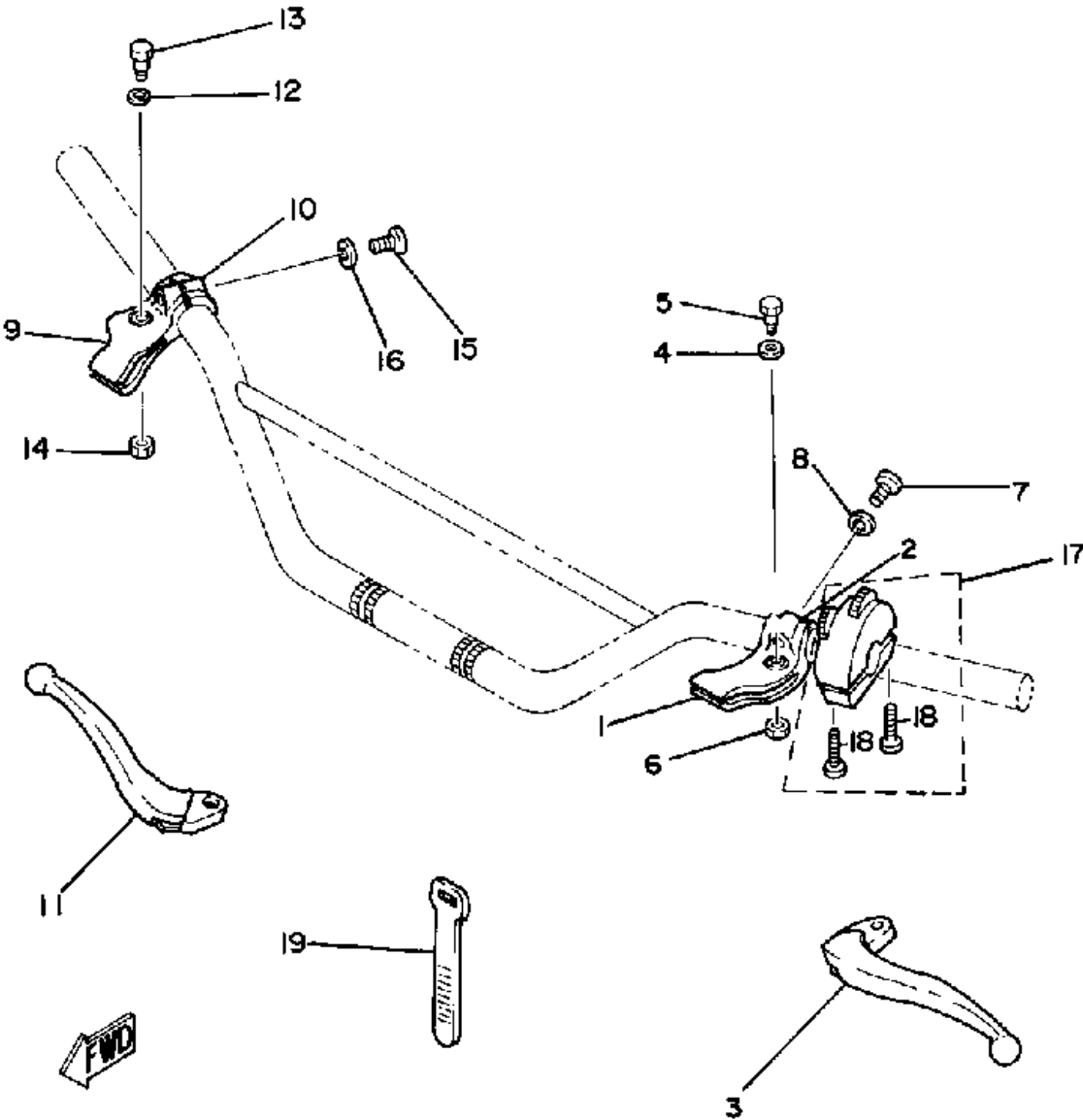

Ref. No.	Part Number	Description	Qty	Remarks
1	5F6-82911-00-00	HOLDER, LEVER 1	1	
2	4V4-82913-00-00	HOLDER, LEVER LOWER 1	1	
3	23X-83912-00-00	LEVER 1	1	
4	90201-08083-00	WASHER, PLATE	1	
5	90109-06797-00	BOLT	1	
6	95601-06100-00	NUT, U	1	
7	98506-05020-00	SCREW, PAN HEAD	2	
8	92906-05100-00	WASHER, SPRING	2	
9	38V-82921-00-00	HOLDER, LEVER 2	1	
10	4V4-82913-00-00	HOLDER, LEVER LOWER 1	1	
11	23X-83922-00-00	LEVER 2	1	
12	90201-08083-00	WASHER, PLATE	1	
13	90109-06797-00	BOLT	1	
14	95601-06100-00	NUT, U	1	
15	98506-05020-00	SCREW, PAN HEAD	2	
16	92906-05100-00	WASHER, SPRING	2	
17	3R8-83973-00-00	SWITCH, HANDLE 3	1	
18	90157-05057-00	SCREW, PANHEAD	2	
19	437-83936-01-00	BAND, SWITCH CORD	2	

## IT175H 1981 SERVICE DATA

<b>MODEL - IBM I.D. NUMBER</b>	IT175H	3R6
Initial Engine Number / Frame Number	3R6-020101 / 3R6-020101	
Basic Color(s)	White	
Fuel Type / Fuel Tank Capacity / Reserve Capacity	Premium / 11 Lit. (2.9 Gal.) / ∅	
Dry Vehicle Weight	94 kg (207 lbs.)	
<b>ENGINE TYPE</b>	2-Stroke, Air-Cooled, Reed Valve	
Bore/Stroke/Number Cylinders/Displacement (cc)	66mm / 50mm / 1 / 171cc	
Compression Ratio/Compression Pressure Min~Max	7.9: 1 / ∅	
Piston Skirt Clearance New / Max	0.050 ~ 0.055mm / 0.1mm	
Ring End Gap Top / 2nd / 3rd	0.2 ~ 0.4mm / 0.2 ~ 0.4mm / ∅	
Valve Clearance (Cold) Intake / Exhaust	∅ / ∅	
Oil Pressure Hot / rpm	∅ / ∅	
Oiling System	Premix 16:1 Using Yamalube R*	
Capacity: Dry	∅	
Oil and Filter Change	∅	
Oil Change	∅	
Lubricant: Temp. Above 5°C (40°F)	Yamalube R*	
Temp. Below 15°C (60°F)	Yamalube R*	
<b>AUTOLUBE - Min Stroke / Color Code</b>	∅	
Minimum Output @ 200 Cycles	∅	
Maximum Output @ 200 Cycles	∅	
<b>CARBURETOR - Mfr. / Type / I.D. Number</b>	Mikuni / VM34SS / 3R6-00	
Main Jet / Pilot Jet	210 / 60	
Needle Jet / Jet Needle-Clip Position	P-8 / 6F21-4	
Slide Cutaway or Throttle Valve	2.0	
Float Level / Fuel Level	NA / NA	
Idle rpm	∅	
Max CO* / Max HC* / Set CO	∅	
<b>SUSPENSION</b>		
Front Forks: Oil Type / Level / Qty	10 Wt. Fork Oil* / ∅ / 317cc	
Gas Pressure	0 kg/cm <sup>2</sup>	
Spring Length Std	607.5mm	
Monoshock: Oil Type / Qty	Not Rebuildable	
Gas Pressure	15 kg/cm <sup>2</sup> (213.4 psi)	
Minimum Brake Lining Thickness	Front: 2.0mm Rear: 2.0mm	
Tire Size (Nominal Pressure)	F: 3.00-21 (Pressure Opt.) R: 4.10-18 (Pressure Opt.)	
<b>TRANSMISSION - Oil Type/Qty Chg/Qty Reassemble</b>	SAE 10W30 SE / 600cc / 700cc	
Primary Drive Type / Teeth / Ratio	Helical Gear / 52-17 / 3.058	
Secondary Drive Type / Teeth / Chain	Chain Drive / 44-12 / DK520DS-100L	
Clutch Friction Plate Thickness Std ~ Min	1.2 ~ 1.0mm	
Clutch Spring Length Std ~ Min	36mm ~ 35mm	
Middle Gear Case Capacity	∅	
Final Gear Case Capacity	∅	
Gear Case Lubricant: Temp. Above 5°C (40°F)	∅	
Temp. Below 15°C (60°F)	∅	
All Weather Conditions	∅	

SERVICE COPY	SER MGR	MECH	MECH	MECH	BINDER
OFFICE COPY	GEN MGR	SALES	PARTS	BINDER	PAGE 1 OF 2

<b>CHARGING SYSTEM</b>	Flywheel Magneto
Battery: Model / Specific Gravity / Charge Rate	∅
Maximum Output	∅
<b>TROUBLESHOOTING</b>	
Field Coil Color Code / Ω	∅
Charge Coil Color Code / Ω	∅
<b>IGNITION SYSTEM</b>	Capacitor-Discharge Ignition
Ignition Timing	2.6mm BTDC
Spark Plug Type	Champion N-2G
Spark Plug Gap / Torque / Cap Ω	0.7mm / 2.5 m-kg / ∅
Point Gap / Condenser Capacitance	∅ / ∅
<b>TROUBLESHOOTING</b>	
Ignition Coil Test Gap / Primary Ω / Secondary Ω	6mm / 1.0 Ω ± 10% / 5.9K Ω ± 20%
Pulser Coil or Pickup Coil Color Code / Ω	Wht-Red ~ Blk / 12.4 Ω ± 10%
Source Coil Color Code / Ω	Brn ~ Blk / 420 Ω ± 10% Red ~ Blk / 13.8 Ω ± 10%
<b>LIGHTING SYSTEM</b>	
Headlight / Taillight / Signal Rating	6V25-25W / 6V5W / ∅
<b>TROUBLESHOOTING</b>	
Lighting Coil Color Code / Ω	Yel-Red ~ Blk / 0.48 Ω ± 10%
<b>TORQUE VALUES</b>	
Front Axle Nut	14 x 1.5: 8.5 m-kg
Front Axle Holder Nut	8 x 1.25: 1.0 m-kg
Rear Axle Nut	14 x 1.5: 8.5 m-kg
Rear Axle Pinch Bolt	∅
Clutch Nut	14 x 1.0: 5.0 m-kg (With Lock Washer)
Drain Plug	14 x 1.25: 2.0 m-kg
Cylinder Head Cover	∅
Cylinder Head:	Nut 8 x 1.25: 2.5 m-kg
	Stud 8 x 1.25: 2.4 m-kg
Engine Mounting Bolts: Engine Front	8 x 1.5: 3.0 m-kg
Engine Center	8 x 1.5: 3.0 m-kg

∅ = Does Not Apply To This Model  
NA = Information Not Available

\*Available From Yamaha Parts Distributors Inc.  
\*For Diagnostic Use Only

<b>CHARGING SYSTEM</b>	Flywheel Magneto
Battery: Model / Specific Gravity / Charge Rate	∅
Maximum Output	∅
<b>TROUBLESHOOTING</b>	
Field Coil Color Code / Ω	∅
Charge Coil Color Code / Ω	∅
<b>IGNITION SYSTEM</b>	Capacitor-Discharge Ignition
Ignition Timing	2.6mm BTDC
Spark Plug Type	Champion N-2G
Spark Plug Gap / Torque / Cap Ω	0.7mm / 2.5 m-kG / ∅
Point Gap / Condenser Capacitance	∅ / ∅
<b>TROUBLESHOOTING</b>	
Ignition Coil Test Gap / Primary Ω / Secondary Ω	6mm / 1.0 Ω ± 10% / 5.9K Ω ± 20%
Pulser Coil or Pickup Coil Color Code / Ω	Wht-Red ~ Blk / 12.4 Ω ± 10%
Source Coil Color Code / Ω	Bm ~ Blk / 420 Ω ± 10% Red ~ Blk / 13.8 Ω ± 10%
<b>LIGHTING SYSTEM</b>	
Headlight / Taillight / Signal Rating	6V25-25W / 6V5W / ∅
<b>TROUBLESHOOTING</b>	
Lighting Coil Color Code / Ω	Yel-Red ~ Blk / 0.48 Ω ± 10%
<b>TORQUE VALUES</b>	
Front Axle Nut	14 x 1.5: 8.5 m-kG
Front Axle Holder Nut	8 x 1.25: 1.0 m-kG
Rear Axle Nut	14 x 1.5: 8.5 m-kG
Rear Axle Pinch Bolt	∅
Clutch Nut	14 x 1.0: 5.0 m-kG (With Lock Washer)
Drain Plug	14 x 1.25: 2.0 m-kG
Cylinder Head Cover	∅
Cylinder Head:	Nut 8 x 1.25: 2.5 m-kG Stud 8 x 1.25: 2.4 m-kG
Engine Mounting Bolts: Engine Front	8 x 1.5: 3.0 m-kG
Engine Center	8 x 1.5: 3.0 m-kG

∅ = Does Not Apply To This Model  
 NA = Information Not Available

\*Available From Yamaha Parts Distributors Inc.  
 \*For Diagnostic Use Only